



IWAKI **Self-priming Magnetic Drive Pump**

SMX-F Series

Instruction Manual

⚠Read this manual before use of product

Thank you for selecting an Iwaki SMX-F Series Self-priming Magnetic Drive Pump. This instruction manual deals with "*Safety instructions*", "*Outline*", "*Installation*", "*Operation*" and "*Maintenance*" sections. Please read through this manual carefully to ensure the optimum performance, safety and service of your pump.

Contents

Important instructions	1
Safety instructions	2
<i>Outline</i>	
1. Unpacking & Inspection	6
2. Product outline	6
3. Model code	7
4. Part names	8
5. Overview	11
<i>Installation</i>	
1. Before installation	13
2. Installation location	13
3. Installation	14
4. Pipework	15
5. Wiring	18
<i>Operation</i>	
1. Operational precautions	20
2. Before operation	21
3. Preparation	23
4. Operation	24
<i>Maintenance</i>	
1. Troubleshooting	27
2. Maintenance & Inspection	28
3. Spare & Wear parts	32
4. Disassembly & Assembly	35



This instruction manual should be kept on hand by the end user for quick reference.

Contact us or your nearest dealer if you have any questions.

Important instructions

For the Safe and Correct Handling of the Pump

- "Safety Instruction" section deals with important details about handling of the product. Before use, read this section carefully for the prevention of personal injury or property damage.
- Observe the instructions accompanied with "WARNING" or "CAUTION" in this manual. These instructions are very important for protecting users from dangerous situations.
- The symbols on this instruction manual have the following meanings:

 WARNING	Nonobservance or misapplication of "Warning" sections could lead to a serious accident which may result in death.
 CAUTION	Nonobservance or misapplication of "Caution" sections could lead to a personal injury or property damage.

Types of Symbols



Indicates that "Warning" or "Caution" must be exercised. Inside this triangle, a concrete and practical image provided as a warning or caution message is depicted.



Indicates a prohibited action or procedure. Inside or near this circle, a concrete and practical image of the activity to be avoided is depicted.



Indicates an important action or procedure which must be performed or carried out without fail. Failure to follow the instructions herein can lead to malfunction or damage to the pump.

For exportation

Technology related to the use of goods in this instruction manual falls in the category of technology contained in the Foreign Exchange Order Attachment, which includes complementary export control of technology. Please be reminded that export license, which is issued by the Ministry of Economy, Trade, and Industry could be required, when this is exported or provided to someone even in Japan.

Safety instructions

WARNING

- **Access limitation**

The magnet drive pump has a pair of strong magnets. A strong magnet field could adversely affect the persons who are assisted by electronic devices such as the pacemaker.



- **Turn off power before work**

Be sure to turn off the power before starting maintenance/repair work. Make sure no one turns on the power while working on the pump, otherwise it may result in a serious accident. Let other people know about the situation by displaying a notice such as "POWER OFF (Maintenance)" near the power switch.



- **Wear protective clothing**

Always wear protective clothing such as eye protection and protective gloves during pipework or dismantlement of the pump.



- **Do not remodel the pump**

A remodelled pump will not be warranted. Also, we are not responsible for a personal injury or property damage due to modification.



- **When handling harmful liquid**

For handling harmful liquids as mentioned below, be sure to conduct daily inspection & maintenance for the prevention of liquid/gas leakage.

1. Explosive or flammable liquid
2. Corrosive liquid
3. Health hazardous liquid



Pay extra attention. Generated gas can stay in the top of front casing.

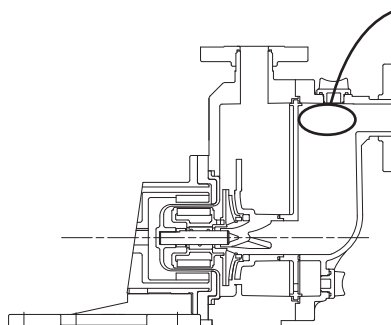

Outline

5. Overview

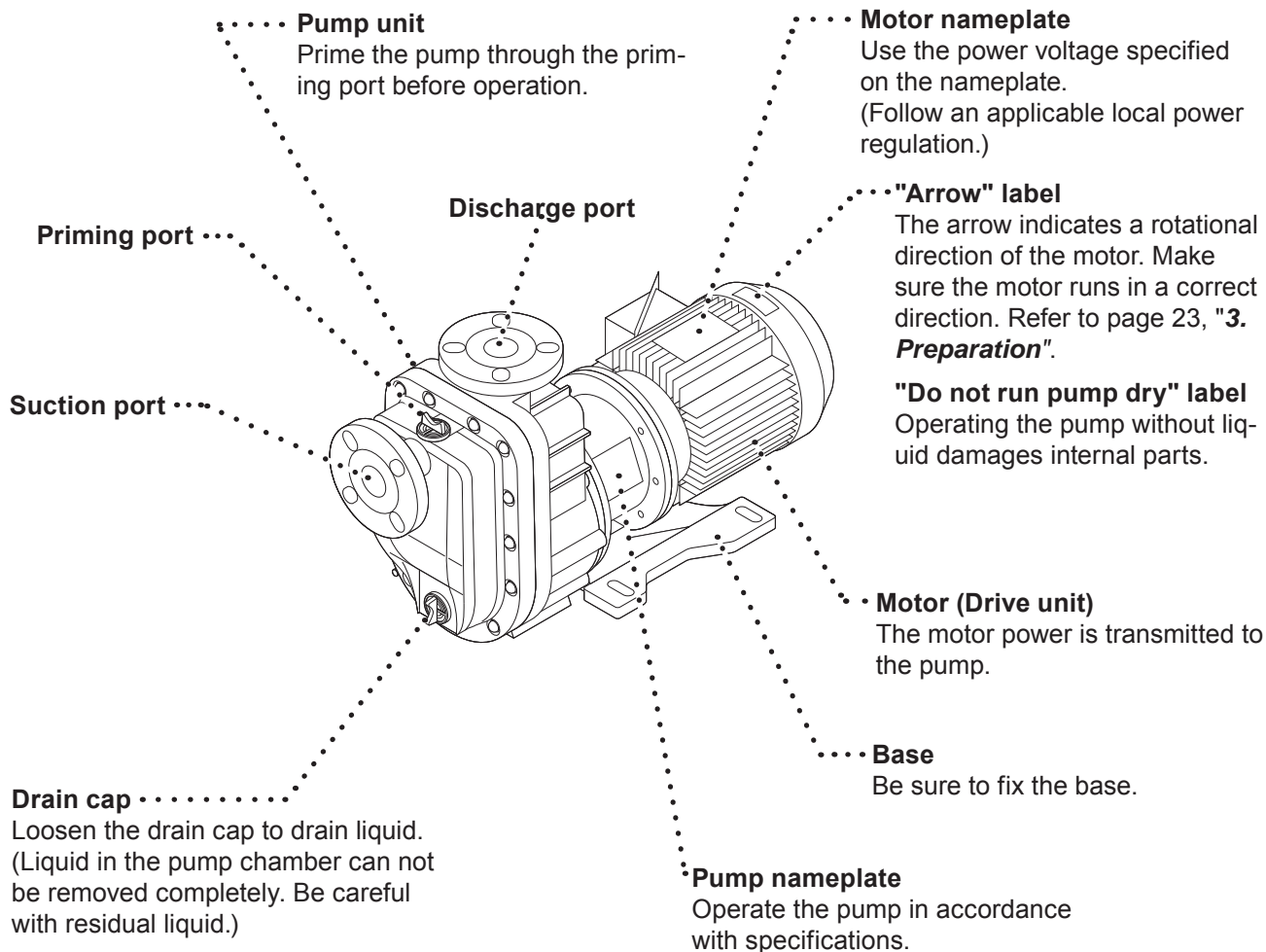

CAUTION

- Wet a cloth with tap water and wring it out for cleaning the pump. Use a neutral detergent for greasy dirt and then rub with a dry cloth. Do not wipe nameplates, labels or pump body with any solvent.
- Turn off main power before cleaning. Be careful not to wet the motor (terminal box and fan cover) and wiring. Otherwise electrical shock or short circuit may result.

Installation

1. Before installation	13
2. Installation location	13
3. Installation.....	14
4. Pipework.....	15
5. Wiring.....	18

Installation

1. Before installation

Precautions for electrical wiring and pipework

CAUTION

- **Do not drop the pump**

Do not drop, hit or drag the pump during carrying in or installation.



- **Ventilation**

Poisoning may result when handling an odorous or a harmful liquid. Keep good ventilation in your working area.



- **Do not hit plastic pump parts**

The front case, rear case and base are plastics. Always keep the plastic parts free from an impact.



- **Keep the pump free from pipe weight**

Plastic pump parts may deform or break. Always support pipework so as not to weigh the pump.



- Install the pump according to a drawing and specification.
- Keep a wide working space for convenience in maintenance.

2. Installation location

Select an installation location under the following conditions for the prevention of damage and deformation.

1. Ambient temperature between 0 - 40 °C
2. A location free from water influx at any time of an accident or casualty
3. A location provided with plumbing equipment
4. Humidity between 35 - 85%RH (Keep good ventilation.)
5. A location free from wind & rain (Except outdoor use)
6. A clean atmosphere
7. Non freezing in winter

Installation

3. Installation

Check if installation doesn't adversely affect facility, surrounding equipment and the pump.

Install the pump according to the following instructions to ensure the optimum performance, safety and service.

■ Installation location

- Keep a wide working space for convenience in installation and maintenance.
- Select a flat & rigid floor/foundation where is free from vibration and contortion.
- Select a location free from the possibility of floods.
- Optimize layout for convenience in carrying in and out.
- Install a chemical protective barrier for unexpected chemical outflow.

■ Pump position

Install the pump according to the following instructions.

- Install the pump as close to a supply tank and a liquid level as possible.
- The maximum priming lift is 4m, however, try to keep a priming lift low as much as possible.

NOTE: The maximum priming lift varies with liquid characteristics, specific gravity, liquid temperature and suction line length. Contact us for detail.

See "**4. Pipework**" for more information on pipework. The pipework section describes a basic layout and precautions.

■ Foundation work

- Use a level to check if a foundation is flat. Securely fix the pump by foundation bolts.
- Insert a shim if there is a gap between the base bottom and foundation surface.
- The foundation should be larger than a pump base footprint.
- See the diagram & instructions below for mounting the base on a foundation.

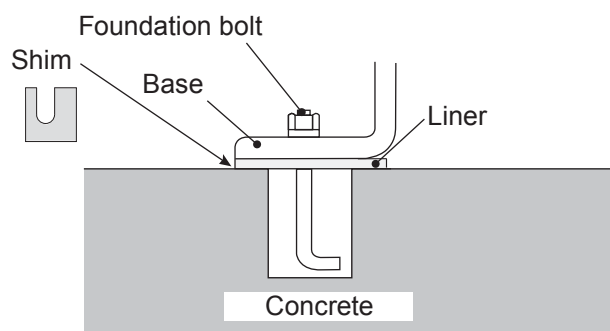

<Foundation work procedure>

- a. Place the pump onto a foundation. Insert liners between the base bottom and foundation surface to keep a mortar injection space.
- b. Screw nuts in foundation bolts until three threads appear after the nuts. And then insert the bolts in threaded holes.
- c. Place a level on the pump base to see flatness. Inject cement mortar into the threaded holes and wait for three days until it has hardened.
- d. Remove the liners after cement mortar has hardened and check flatness again. Then tighten the nuts on the foundation bolts. If there is a gap insert a shim.

Installation

4. Pipework

Foreign matters such as sand and scale may enter pipework while you are working. They may cause fatal damage to the pump. Be sure to blow them out before operation. Also, do not apply adhesive too much or leave a screw or nut.

If pipework directly weighs on the pump, plastic parts may be deformed. Be sure to install pipe supports.

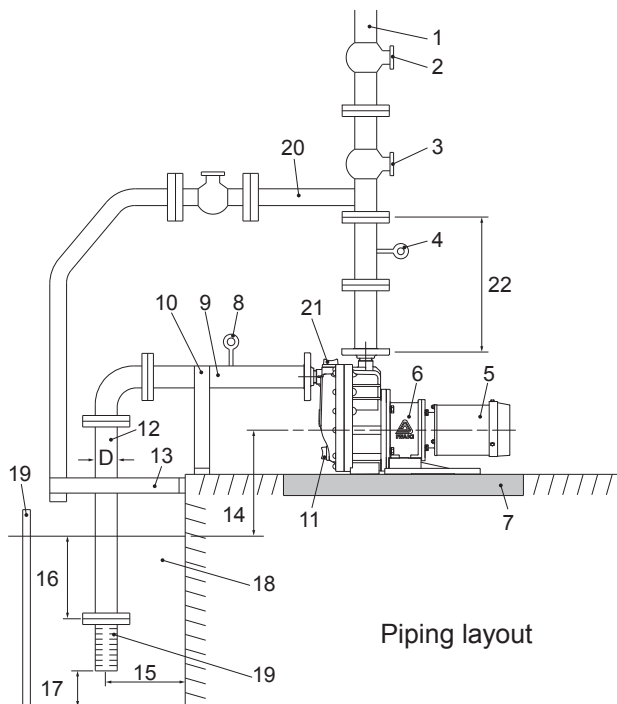

1. Discharge pipe
(Support pipework to keep the pump free of piping weight.)
2. Gate valve
3. Check valve
4. Pressure gauge
5. Motor
6. Pump
7. Drain ditch
8. Vacuum gauge
9. Suction pipe (Pipe diameter: D)
(Horizontal sections should be shortest and laid on a rising gradient of 1/100 toward the pump)
10. Pipe support
11. Drain cap
12. Suction pipe (Pipe diameter: D)
13. Pipe support
14. Priming lift (max 4m)
15. 1.5 times larger than D
16. 500 mm or more
17. 1.5 times larger than D
(The distance must be more than 500 mm if sand or mud accumulates.)
18. Supply tank
19. Filtering screen
20. Air vent pipe
21. Priming port (cap)
22. Straight section (500mm or more)

■ Suction line

1. A suction pipe bore should be equal to the pump inlet bore (25A,40A or 50A)

If a suction pipe bore is larger than a pump inlet bore, air volume in a suction line becomes so large that the pump can not make self-priming.

2. Suction line length should be within 4.7m in total (Horizontal and vertical pipe line)

Suction line length is the entire length from the pump inlet to the lowest pipe end, including horizontal parts. If a suction line is longer than 4.7m, air volume becomes large in the line. This prevents the pump from sucking liquid even if the priming lift is 4m or less (the maximum priming lift is 4m). Also, If a supply tank is too small, a liquid level can fluctuate significantly.

3. End of a suction line

- The end of a suction line should be at least 500mm below a liquid level for the prevention of air ingress.
- The distance from the lowest pipe end to a tank bottom should be 1.5 times longer than a suction pipe bore.
- Provide a screen in a supply tank for the prevention of foreign matter interfusion (Clean the screen periodically).

4. A suction gate valve should be installed

In a flooded suction system, install a gate valve on a suction line for easier overhaul & inspection.

5. Make sure joints on a suction line are secure and air doesn't come in. Try to reduce the number of joints. If air enters a suction line, liquid may not be pumped or the pump may break at its worst.

Installation

6. Do not make an arched line in order to prevent air from being trapped. A suction line right before the pump inlet should be laid on a rising gradient of 1/100 toward the pump.

■ Discharge line

1. A discharge pipe bore is related to pipe resistance

Pipe resistance increases if a discharge pipe bore is too narrow, so that an intended flow can not be obtained. The increment of pipe resistance also affects self-priming performance when degassing is interrupted. Install a 500mm straight pipe right after the pump outlet.

2. A discharge gate valve should be installed

Install a gate valve on a discharge line not only for adjusting a discharge flow but also smooth operation, inspection and maintenance. Make sure that a discharge or an air vent line is open during self-priming operation.

3. A check valve should be installed

When selecting a check valve, check the pressure limit in relation to the influence of water hammer or back flow onto the pump.



- A discharge line is too long.
- Actual discharge head (Static discharge head plus Discharge pipe resistance) is more than 15m.
- The end of a discharge line is 9m higher than a liquid level.
- Several pumps are running in parallel.

4. An air vent line should be arranged in the following cases

- A horizontal discharge line is 10m or more.
- A check valve is installed. Otherwise self-priming can not be performed.
- A discharge line is not at atmospheric pressure. Otherwise self-priming can not be performed.

5. A pressure gauge should be installed

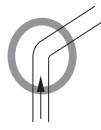
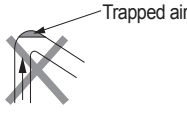
Install a pressure gauge on a discharge line for monitoring operating conditions.

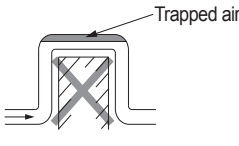
Good conditions	Unacceptable conditions
 <p style="text-align: center;">Ascension</p>	 <p style="text-align: center;">Declination</p>
 <p style="text-align: center;">Inverted arch piping</p>	 <p style="text-align: center;">Arched piping</p>

Installation

■ Tightening torque between the pump and pipework

- Flush the inside of pipes before connection.
- Connect the pump to pipework via inlet and outlet flanges according to the table below.

(This table is based on use of metal pipe flanges with rubber gaskets.)

Bolt size	Tightening torque (N·m)
M16	20

- Tighten bolts diagonally at even torque.

■ Piping load and momentum

Try not to apply a heavy load to the pump inlet and outlet flanges. Permissible piping weight and moment to the pump are as below.

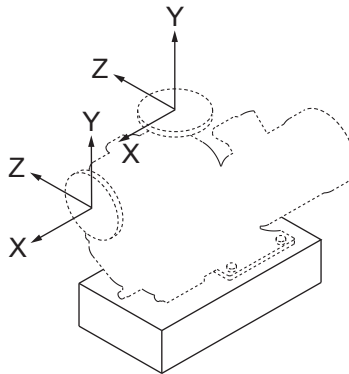

Permissible stress to outlet flange

Load direction	Pipe dia. (mm)	
	25	40
	Load	
	kN	
Fx	0.10	0.15
Fy: compression	0.15	0.20
Fy: tension	0.10	0.10
Fz	0.10	0.15

Permissible stress to inlet flange

Load direction	Pipe dia. (mm)	
	25	40, 50
	Load	
	kN	
Fx	0.10	0.10
Fy	0.10	0.15
Fz	0.10	0.15

Permissible moment to outlet flange

Load direction	Pipe dia. (mm)	
	25	40
	Moment	
	kN·m	
Mx	0.02	0.05
My	0.05	0.10
Mz	0.05	0.10

Permissible moment to inlet flange

Load direction	Pipe dia. (mm)	
	25	40, 50
	Moment	
	kN·m	
Mx	0.05	0.10
My	0.02	0.05
Mz	0.05	0.10

Installation

5. Wiring

1. Electrical wiring and any work on power source must be performed by qualified persons only. We are not responsible for any injury and damage due to noncompliance with this notice. Contact us as necessary.
2. Install an electromagnetic switch according to motor specifications (voltage, capacity, etc.).
3. The pump and motor do not have protection equipment. Install an overcurrent protection or earth leakage breaker according to motor specification.
4. Electromagnetic switches and push buttons should be installed away from the pump.
5. If the pump is used out of doors, protect switches from rainwater.
6. Outdoor use motors (Indoor use motors can not be installed out of doors).
Outdoor use motors can also be used in doors. Protect the motor and electrical power distribution equipment from possible damage, taking account of act of providence.

■ Electrical motor











1. Check/adjust the motor as well as pump before operation.
2. Read through a motor instruction manual before operation.
3. Check the rotational direction of the motor after wiring.
4. Be sure to earth the motor.

Operation

<i>1. Operational precautions.....</i>	<i>20</i>
<i>2. Before operation</i>	<i>21</i>
<i>3. Preparation</i>	<i>23</i>
<i>4. Operation.....</i>	<i>24</i>

Operation

1. Operational precautions

 CAUTION			
<ul style="list-style-type: none"> • Never run the pump dry or shut off a suction valve during operation. This may damage internal parts. 	 Prohibit		
<ul style="list-style-type: none"> • Stop the pump immediately when it is running under cavitation*¹. An abnormal sound of water flowing through a pipe or a significant pressure change (see a pressure gauge) is a sign of cavitation. Also do not continue to run the pump when air is sucked from a suction line. 			
<ul style="list-style-type: none"> • Stop the pump immediately when the magnet coupling*² is disconnected*³. The impeller does not rotate while the motor keeps rotating in this condition. Thus, liquid is not pumped. 			
<ul style="list-style-type: none"> • Keep liquid temperature change within 80 °C at any time during operation or stop. 			
<ul style="list-style-type: none"> • (In a flooded suction system,) Start the pump with closed-discharge operation (close the discharge gate valve) in order to avoid water hammer. And then gradually open the discharge gate valve to adjust the flow. 			
<ul style="list-style-type: none"> • Do not keep the closed-discharge operation for one minute or longer. Otherwise, liquid temperature rises in the pump and damages internal parts. 	 Caution		
<ul style="list-style-type: none"> • If the power is interrupted while the pump is running, switch off the pump immediately and close discharge valves. Otherwise, water hammer may occur and damage the pump. 			
<ul style="list-style-type: none"> • Take extra care so that a discharge pressure does not exceed the pump limit. Refer to page 22, "6. Maximum operating pressure". 	 Caution		
<ul style="list-style-type: none"> • Do not touch the pump surface when a high temperature liquid is transferred. The pump surface becomes very hot. Take a protective measure against burn. 			
<ul style="list-style-type: none"> • The noise level is shown below. In case the pump noise affects human health or communication to secure a safety, provide a noise reduction cover. Be careful not to reduce the cooling effect by a motor fan. 			
<table border="1" style="margin-left: auto; margin-right: auto;"> <tr> <td>Noise level</td> <td>80 dB</td> </tr> </table>	Noise level	80 dB	
Noise level	80 dB		

Word & Terms: *1 Air bubbles caused by a negative pressure in the pump, accompanied with vibration and noise: Performance deterioration or parts corrosion results.

*2 A pair of the drive magnet and the magnet capsule

*3 A state that the combination of the impeller and magnet capsule units does not rotate in sync with the drive magnet.

Operation

WARNING

- **Do not remodel the pump**

A remodelled pump will not be warranted. Also, we are not responsible for a personal injury or property damage due to any modification.



CAUTION

- **Be sure to prime the pump before operation**

Always prime the pump when the pump is empty, for example, the pump is used for the first time or after dismantlement/assembly. Running the pump without priming water, internal parts are excessively worn by friction heat and fatal pump damage results.



- **Do not run pump dry**

Do not run pump dry (Operation without priming water or with a suction valve closed). Otherwise, internal parts are excessively worn by friction heat and fatal pump damage results.



* If the pump runs dry by mistake, turn off power and leave it for more than one hour to cool it down. Quick cooling can give rise to cracks on parts.

* An Iwaki dry run protector, the DR model, is recommended for the prevention of dry running.

- **Do not bring the pump close to a flammable substance**

Keep the pump away from a flammable substance for the prevention of fire.



2. Before operation

Confirm pump performance and specifications prior to operation.

1. Do not run the pump in closed-discharge operation. Always keep the rated minimum flow rate. Also, do not send any medium other than fluid.

Minimum flow rate

SMX-F22, -F44	10L/min
SMX-F54	20L/min

2. Prime the pump before self-priming operation

The SMX-F is a self-priming pump, however, the pump needs to be primed to a certain liquid level before operation. Once the pump is primed, generally the pump doesn't need to be primed at each operation because the pump keeps a needed liquid level for the next self-priming. But then the pump still needs to be primed after a long period of storage (one day or more) or when the self-priming operation was not completed (when the pump stops running before liquid was discharged.).

Minimum liquid volume

SMX-F22□	3.0L
SMX-F44□	4.2L
SMX-F54□	5.4L

NOTE: Do not pour liquid rapidly. Otherwise liquid may overflow.

Operation

3. ON-OFF operation

Frequent ON-OFF operation damages the pump, especially in self-priming operation. Do not make ON-OFF operation more than six times per hour.

4. Handled liquid - Observe the next points

1. Slurry :Slurry can not be handled.
2. Liquid viscosity :Allowable up to 30mPa*s. Ask us for detail.
3. Liquid temperature :0-80°C (Clean water, Non freezing)
Self-priming performance reduces as liquid temperature increases. Allowable liquid temperature varies with chemicals.

NOTE: The pump may not send a bubbly liquid or a liquid with a high vapour pressure.

NOTE: Performance curves on catalogue are based on pumping clean water at a room temperature in a flooded suction system. Contact us for detail.

5. If the magnet coupling (the drive and driven magnets) is disconnected...

Stop the pump immediately. Liquid can not be pumped at all in this state. The magnet force reduces if the pump keeps on running in this condition. Solve problems first and then resume operation. See page 27, "**I. Troubleshooting**".

6. Environmental conditions

Ambient temperature range: 0-40°C

Ambient humidity range: 35-85%

7. Maximum operating pressure

See the table below for the maximum operating pressure at each model. Do not run the pump over the pressure limit. Note liquid of high specific gravity can easily exceed the pressure limit during operation.

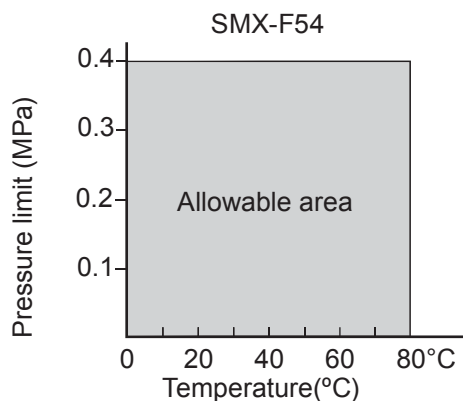
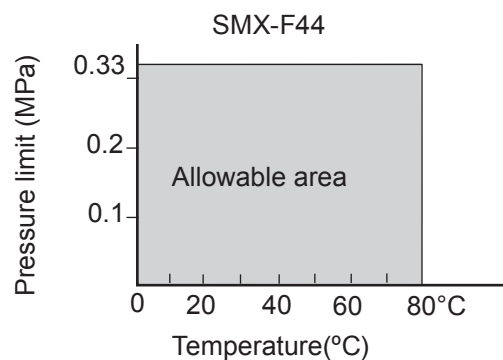
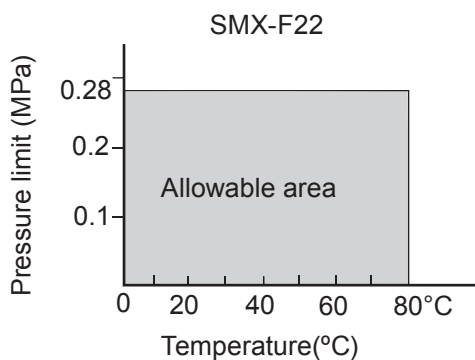

Operation

3. Preparation

■ Preparations for operation

1. Check the pump and pipework before operation.

- a. Check there are no foreign matters in the supply tank and pipework. If foreign matters are stuck in a suction line, the pump may break. Do not leave any waste of bond, sealing materials and screws/nuts as well.
- b. Check pipework joints are tight enough so that air does not enter pipework. Take extra care to a suction line because the suction side is a vacuum during operation.
- c. Check the bolts on the pump unit and retighten them as necessary.

2. Follow the procedures below to start the pump at the first operation or after a long period of storage.

- a. Detach the cap on the self-priming port. Fill the pump with liquid.

 CAUTION
--

Do not pour liquid rapidly. Otherwise liquid may overflow.
--

- b. Tighten the cap securely in order to prevent entrained air.

- c. Run the motor for a moment in order to check if the motor rotates according to the arrow label*¹ (Clockwise, seen from the motor fan). If the motor rotates in reverse, interchange two of 3-phase power.

■ Precautions for starting/stopping the pump

(In case the pump is in a flooded suction system.)

Follow the procedures below when starting/stopping the pump for the prevention of water hammer*².

Take extra care when a discharge line is long.

a. When starting the pump

First, prime the pump. Then turn on power to start operation with a discharge valve fully closed.

And then gradually open the discharge valve and adjust a flow rate to a specified point.

b. When stopping the pump

Gradually close a discharge valve. Turn off power and stop the pump after the valve is fully closed.

NOTE: When using a solenoid valve, set it to close slowly.

Word & Terms: *1 An arrow label is placed on the upside of the motor fan cover.

*2 Shutting off a discharge line at once, liquid pressure change causes an impact pressure, accompanying impact noise and vibration. This phenomenon is called water hammer. Water hammer damages the pump & pipework and may cause leakage.

Operation

4. Operation

■ Starting process

Operate the pump by the following procedure.

No.	Operation Procedure	Remarks
1	<ul style="list-style-type: none"> Close or open valves. 	<ul style="list-style-type: none"> Open suction valves fully. Close a discharge valve fully (in a flooded suction system). Open discharge valves fully (in a suction lift system).
2	<ul style="list-style-type: none"> Prime the pump. 	<ul style="list-style-type: none"> Check that the pump is filled with liquid. If not, fill the pump with liquid. After priming, close a discharge valve fully (in a flooded suction system). After priming, open discharge valves fully (in a suction lift system).
3	<ul style="list-style-type: none"> Check the motor for correct rotating direction. Turn on power and then immediately switch off the power. 	<ul style="list-style-type: none"> Supply power to run the pump only for checking the rotational direction. (Correct direction is indicated with an arrow on the motor.) Check if the motor fan smoothly stops after the power is turned off. <p>⚠ CAUTION</p> <ul style="list-style-type: none"> The pump can be damaged when running in reverse rotation for a long time. If the motor fan does not stop smoothly, internal parts may contact each other. Check the inside of the pump. If the pump runs in reverse rotation for a long time, the primed liquid may flow back. In this case prime the pump again.
4	<ul style="list-style-type: none"> Turn on power and start the pump to adjust discharge pressure and capacity. Observe the minimum discharge capacity. See below. 	<ul style="list-style-type: none"> In a flooded suction system Run the pump with a discharge valve closed. Once the pressure gauge reaches shut-off pressure, open the discharge valve gradually to obtain a specified discharge pressure (or discharge capacity). NOTE: Start to open/close a discharge valve gradually to adjust discharge pressure within one minute after the pump starts to run. Always check a discharge pressure gauge (or adjust discharge capacity by checking a flow meter). In a suction lift system Start the pump with discharge valves full open. When air is expelled, start to close a discharge valve gradually to obtain a specified discharge pressure. Note that it takes a while to completely expel air out of the pump and a suction line. <p>⚠ CAUTION</p> <p>Opening a valve suddenly, the motor may be over-loaded. Open a valve, checking amperage.</p> <p>Do not operate the pump below the minimum discharge capacity.</p> <ul style="list-style-type: none"> ▶ Minimum discharge capacity: 10L/min for SMX-F22/-F44, 20L/min for SMX-F54 • Observe the minimum discharge capacity for the prevention of continuous closed-discharge operation. This rule holds true to not only manual operation but also automatic operation. <p>⚠ CAUTION</p> <p>Do not run the pump longer than one minute with a discharge valve fully closed.</p>

Operation

No.	Operation Procedure	Remarks
5	<p><Points to be checked></p> <p>Check a flow meter and confirm that pump operation is as per specifications during operation.</p>	<ul style="list-style-type: none"> • Use a flow meter to see if the pump runs at a specified point. • If a flow meter is not available, check a specified point from discharge pressure, suction pressure and current value, taking account of pipe resistance.

⚠ CAUTION

- In case of trouble, turn off power immediately and solve problems. See "Troubleshooting".
- If the power is interrupted while the pump is running, switch off the pump immediately and close discharge valves.

■ Stopping process

No	Operation Procedure	Remarks
1	<ul style="list-style-type: none"> • Close a discharge valve gradually. 	<ul style="list-style-type: none"> • Do not close a discharge valve instantly whether manual or automatic operation. Otherwise, the pump may be damaged by water hammer action which is possible when a discharge line is long. When using a solenoid valve set it to close slowly.
2	<ul style="list-style-type: none"> • Turn off power and stop pump operation. 	<ul style="list-style-type: none"> • Check that the motor stops slowly and smoothly. If it does not stop smoothly, inspect the inside of the pump. • The pump is designed to keep enough liquid for the next self-priming operation by siphon cut. So generally the pump needs to be primed only once at the initial operation stage, however, check a liquid level in the pump after a long period of stoppage. • If the pump stops before self-priming is completed (before liquid is discharged.), the pump needs to be primed again for next self-priming operation.
3	<p><Leaving the pump stop></p> <ul style="list-style-type: none"> • A liquid level in the pump may decrease if the pump is not operated for a long period (a day or more). In such a case, prime the pump before operation. • Liquid in the pump may freeze and consequently damage the pump in winter. Drain liquid before storage. Be careful when draining harmful liquid. • Use a heater to prevent liquid from freezing when the pump is stopped for a while in an extremely cold region. • We recommend covering the pump while the pump is not operated for a long period or during storage. 	

Maintenance

<i>1. Troubleshooting</i>	<i>27</i>
<i>2. Maintenance & Inspection.....</i>	<i>28</i>
<i>3. Spare & Wear parts</i>	<i>32</i>
<i>4. Disassembly & Assembly.....</i>	<i>35</i>

Maintenance

1. Troubleshooting

If you can not find out the root cause of failure, contact us.

Trouble	Cause	Troubleshooting
Self-priming is not performed or too slow. The pump does not perform the second self-priming operation.	<ul style="list-style-type: none"> • Priming liquid level is too low. • The pump is running dry. 	<ul style="list-style-type: none"> ○ Stop the pump and feed a sufficient amount of priming liquid. Then restart the pump.
	<ul style="list-style-type: none"> • A discharge valve is closed. • An air vent line is closed. 	<ul style="list-style-type: none"> ○ Open the valve fully and start the pump.
	<ul style="list-style-type: none"> • Air enters the pump from suction line connections. • Supply tank liquid level is too low. 	<ul style="list-style-type: none"> ○ Check connections on a suction line. ○ Fill a supply tank.
	<ul style="list-style-type: none"> • Discharge line is not at atmospheric pressure. 	<ul style="list-style-type: none"> ○ Install an air vent line. ○ Reconsider discharge line layout.
	<ul style="list-style-type: none"> • The magnet coupling is disconnected*. (The impeller unit does not rotate.) 	<ul style="list-style-type: none"> ○ Check amperage to see if the pump is not overloaded. ○ Check any foreign matters are not stuck between the impeller and the magnet capsule. ○ Check for viscosity or load change. ○ Check voltage and resume operation. <p>NOTE: Contact us if disconnection often occurs.</p>
	<ul style="list-style-type: none"> • Stroke speed is insufficient. • The pump rotates in reverse. 	<ul style="list-style-type: none"> ○ Check wiring & the motor. ○ Exchange connected wires.
	<ul style="list-style-type: none"> • The pump is positioned too high. 	<ul style="list-style-type: none"> ○ Install the pump within the max priming lift. ○ Check that a liquid level is not too low.
	<ul style="list-style-type: none"> • Specific gravity or viscosity is not suitable. • Liquid temperature is too high. 	<ul style="list-style-type: none"> ○ Check liquid temperature, SG and viscosity. ○ Reduce liquid temperature or shorten priming lift.
	<ul style="list-style-type: none"> • A suction line is too long. 	<ul style="list-style-type: none"> ○ Shorten the suction line.
	<ul style="list-style-type: none"> • Frequency mismatch 	<ul style="list-style-type: none"> ○ Match frequency to the pump.
	<ul style="list-style-type: none"> • Suction line is blocked with foreign matters. • Discharge line is blocked with foreign matters. 	<ul style="list-style-type: none"> ○ Remove foreign matters. ○ Take measures against foreign matter interfusion.
	<ul style="list-style-type: none"> • A suction pipe is crushed. 	<ul style="list-style-type: none"> ○ Change the pipe to new one with higher rigidity.
	<ul style="list-style-type: none"> • A discharge line end and an air vent line end are submerged. 	<ul style="list-style-type: none"> ○ Take the line ends up from a liquid level.
Discharge rate is too low.	<ul style="list-style-type: none"> • A suction line or the pump inlet are blocked with foreign matters. 	<ul style="list-style-type: none"> ○ Remove foreign matters from the pump inlet. ○ Take measures against foreign matter interfusion.
	<ul style="list-style-type: none"> • An air pocket is in a suction line. 	<ul style="list-style-type: none"> ○ Check and adjust the line as necessary.
	<ul style="list-style-type: none"> • The impeller inlet is blocked with foreign matters. 	<ul style="list-style-type: none"> ○ Remove foreign matters.
	<ul style="list-style-type: none"> • Air enters the pump from a suction line. 	<ul style="list-style-type: none"> ○ Check the suction line and retighten connections as necessary.
	<ul style="list-style-type: none"> • A discharge line or the pump outlet is blocked with foreign matters. 	<ul style="list-style-type: none"> ○ Remove foreign matters/scale. ○ Take measures against foreign matter interfusion.
	<ul style="list-style-type: none"> • Pipe resistance is increased due to an air pocket in pipework. 	<ul style="list-style-type: none"> ○ Reconsider pipework layout to remove arched line.
	<ul style="list-style-type: none"> • Actual head & head loss are too high. 	<ul style="list-style-type: none"> ○ Check actual head and head loss, and take necessary measures.
	<ul style="list-style-type: none"> • The motor rotates in reverse direction. 	<ul style="list-style-type: none"> ○ Exchange connected wires.

*A state that the combination of the impeller and magnet capsule units does not rotate in sync with the drive magnet.

Maintenance

Trouble	Causes	Troubleshooting
The motor is overheated.	<ul style="list-style-type: none"> • Voltage has dropped greatly. • Overload • Ambient temperature is too high. 	<ul style="list-style-type: none"> ○ Check voltage and frequency. ○ Check that specific gravity and viscosity are suitable. ○ Keep ventilation around the motor.
The discharge rate has dropped suddenly.	<ul style="list-style-type: none"> • The pump inlet is blocked with foreign matters. 	<ul style="list-style-type: none"> ○ Remove the foreign matters.
The pump vibrates excessively, accompanied by noise.	<ul style="list-style-type: none"> • The base is not anchored firmly. • Installation bolts are loosened. • A suction line is blocked and this is causing cavitation. • The pump bearing is worn or melted. • The magnet capsule or the spindle is damaged. • Dynamic balance of the driving magnet has changed. • Rotating parts come in contact with stationary parts. • The motor bearing is worn. 	<ul style="list-style-type: none"> ○ Fix the base. ○ Retighten the bolts. ○ Get rid of blockage. ○ Replace as necessary. ○ Replace as necessary. ○ Remove the cause or replace the part. ○ Replace as necessary. ○ Replace the bearing or motor.

2. Maintenance & Inspection

 **WARNING**

- Access limitation**

The magnet drive pump has a pair of strong magnets. The strong magnet field could adversely affect the persons who are assisted by electronic devices such as the pacemaker.



Prohibited
- Turn off power during maintenance work**

Risk of electrical shock. Make sure the power source is turned off and the pump and devices are stopped prior to work.



Turning off power
- Wear protective clothing**

Coming in contact with a harmful chemical liquid may cause eye or skin trouble. Wear protective clothing such as a protective mask, goggles, gloves during work.



Wear protective gear

 **CAUTION**

- Do not catch the finger**

The magnet force of the pump is powerful. Take care not to catch the finger in the bracket.



Caution

Maintenance

- ▶ Mark each wire so that the wires can be connected correctly to the motor.
- ▶ Do not disassemble the pump beyond the extent shown on this manual.
- ▶ Make sure to close suction and discharge valves before dismantling/assembling the pump. Clean the inside of the pump as well.
- ▶ The magnet force of the pump is strong. Be careful not to catch the finger in parts. Do not allow iron pieces or powders to stick to the magnets.

■ Daily inspection

1. Always check for leakage before pump operation. Do not run the pump when liquid leaks.

CAUTION

The pump unit mounting bolts/nuts may loosen in the initial operation phase or under an operating condition where the temperature fluctuates greatly. Check the bolts/nuts periodically and tighten them as necessary.

Tightening torque for the pump unit mounting bolts/nuts are shown on page 41. Tighten the bolts by applying equal torque.

2. Check whether the pump operates smoothly without abnormal noise or vibration.
3. Check a liquid level in the supply tank and a suction pressure.
4. Check that discharge capacity and a motor current value are as per specifications on the nameplate during operation.

NOTE A discharge pressure is in proportion to the specific gravity of liquid. The cock of the pressure gauge or vacuum gauge should be opened only when measurement is carried out. Close it right after measurement. If the cock remains open during pump operation, the meter mechanism may be affected by the abnormal pressure rise caused by water hammer action.

5. If a spare pump is stored, run the pump from time to time to keep it ready for operation at any time when needed.
6. Check discharge pressure, discharge capacity, and motor power supply voltage to see if they do not fluctuate during pump operation. See page 27 & 28 "**1. Troubleshooting**" as necessary.

Maintenance

■ Periodic inspection

To ensure efficient and smooth operation, perform periodic inspection. Be careful not to damage internal sliding parts and plastic parts when dismantling the pump.

- Inspect the pump every six months, logging inspection records.
- For 24-hour continuous operation, inspect the pump every two months.
- Be sure to turn off power before dismantling the pump. Replace wear parts according to estimated parts lives.

The magnetic force of the drive magnet and the magnet capsule is strong. Be careful not to catch the finger. Do not put electrical devices such as a watch and a mag card close to the magnets.

Interval	Part names	Inspection items	Measures
Every six months (Maintain an inspection record)	(Drive magnet unit) Drive magnet Hex. socket set screw	<ul style="list-style-type: none"> • Wear trace • If the drive magnet is correctly mounted by hex. socket set screws and they are not loose. • Decentering of magnet and motor shaft (Max.1/10mm) 	<ul style="list-style-type: none"> ○ Finding wear trace, contact us. ○ Reset the drive magnet to the motor shaft and retighten the screws. ○ Retighten the hex. socket set screws or replace the drive magnet (Contact us).
	Rear casing Rear thrust	<ul style="list-style-type: none"> • Wear tracks on an inner surface • Cracks • Wear of the rear thrust • Contamination in rear casing 	<ul style="list-style-type: none"> ○ Contact us. ○ Replace as necessary. ○ Contact us. ○ Remove contamination.
	(Magnet capsule unit) Magnet capsule Bearing	<ul style="list-style-type: none"> • Wear tracks on the rear end or side face of the magnet capsule • Cracks on the rear end or side face of the magnet capsule • Wear of the bearing • Loose fit of the impeller unit 	<ul style="list-style-type: none"> ○ Contact us. ○ Contact us. ○ Replace as necessary. ○ Replace or contact us.
	(Impeller unit) Impeller Mouth ring	<ul style="list-style-type: none"> • Wear of the mouth ring • Cracks • Contamination in the impeller • Impeller deformation 	<ul style="list-style-type: none"> ○ Replace as necessary. ○ Replace as necessary. ○ Remove contamination. ○ Replace as necessary.
	Front case Rear case Liner ring	<ul style="list-style-type: none"> • Contamination • Cracks • Wear, cracks and wear tracks on a liner ring • Swelling or a crack on O ring • Wear tracks on an unlikely portion 	<ul style="list-style-type: none"> ○ Remove contamination. ○ Replace as necessary. ○ Contact us. ○ Replace as necessary. ○ Contact us.
	Spindle	<ul style="list-style-type: none"> • Cracks • Wear 	<ul style="list-style-type: none"> ○ Replace as necessary. ○ Replace as necessary.

Maintenance

■ Wear limit of the bearing and spindle

Check wear degree of the bearing and spindle.

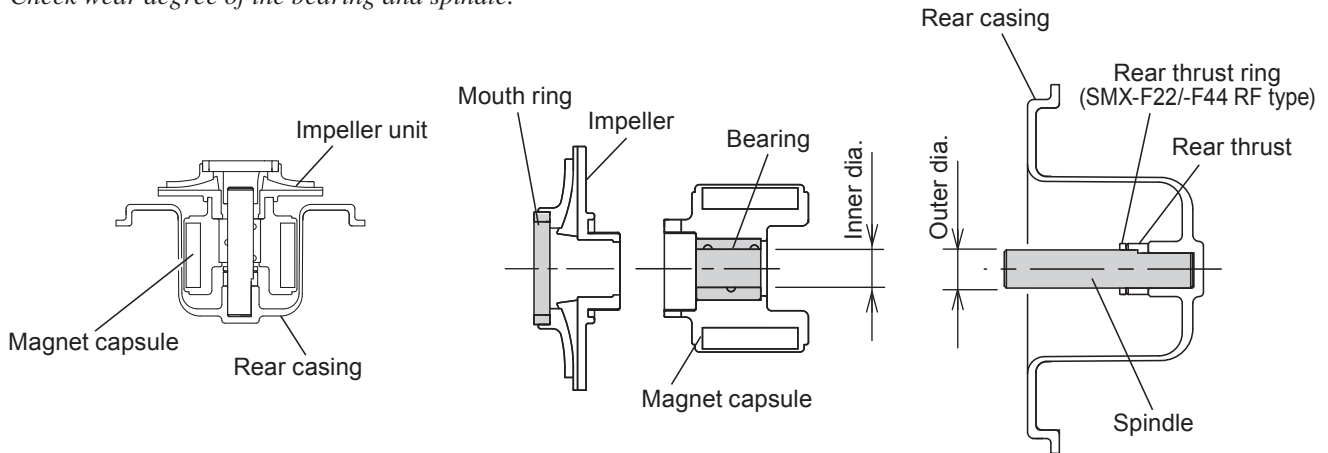

Parts	Model	SMX-F22,44			SMX-F54		
		Dia. at shipment	Wear limit	Wear depth	Dia. at shipment	Wear limit	Wear depth
Bearing inner dia.		ø18.0mm	ø19.0mm	1.0mm	ø24.0mm	ø25.0mm	1.0mm
Spindle outer dia		ø18.0mm	ø17.0mm	1.0mm	ø24.0mm	ø23.0mm	1.0mm

1. Above values show wear limit of the bearing and spindle.

2. If the clearance between the bearing and the spindle exceeds 1 mm, either of them, whichever has greater wear, should be replaced regardless of the wear limit.

<Example>

Inner diameter of bearing is Ø18.7

Wear depth is 0.7mm (Within wear limit)

Outer diameter of spindle is Ø17.5

Wear depth is 0.5mm (Within wear limit)

Clearance is 1.2mm. In this case replace the bearing, 'cause its wear is deeper than the spindle.

3. Sliding parts may suffer initial wear in an initial operation phase but this is not abnormal. Initial wear stops within approximately 100 hours.

■ Wear limit of mouth ring

Check wear degree of the mouth ring.

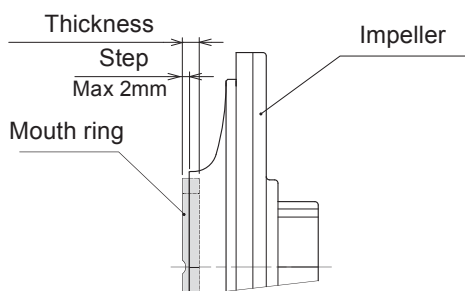

Initial thickness	Wear limit
7.5 mm	5.5 mm

NOTE: The mouth ring is 2 mm forward from the impeller when shipped. Before the step has reduced to 0 mm, replace the impeller unit.

Maintenance

3. Spare & Wear parts

Appropriate spare parts are necessary for a long period of continuous operation. We recommend that wear parts be always in stock. Place an order for spares with the following information.

1. Part names and part number (See page 8, 9 & 10 "4. Part names".)
2. Pump model identification code and manufacturing number (See pump nameplate.)
3. Drawing number if you have our approval drawing

■ Spare parts list (SMX-F22)

No	Part names		Material	Part codes			
				SMX-F220	SMX-F221	SMX-F222	
1	Front case		CFRETFE	SMF0001			
2	Rear case (for CF•RF)	Impeller code	V	CFRETFE	SMF0002	---	
			Y	CFRETFE	SMF0003	---	
			T	CFRETFE	---	SMF0052	
			X	CFRETFE	---	SMF0052	
	Rear case (for KK)	Impeller code	V	CFRETFE	SMF0004	---	
			Y	CFRETFE	SMF0005	---	
			T	CFRETFE	---	SMF0053	
			X	CFRETFE	---	SMF0053	
3	Rear casing		CFRETFE	SMF0006			
4	Volute spacer	Impeller code	V	CFRETFE	SMF0007	---	
			Y	CFRETFE	SMF0008	---	
			T	CFRETFE	---	SMF0054	
			X	CFRETFE	---	SMF0007	
6	Plate		CFRETFE	SMF0009			
7	Cap		CFRETFE	SMF0010			
8	Drain cap		CFRETFE	SMF0011			
9+29	Impeller UNIT (for CF•RF)	Impeller code	V	CFRETFE	SMF0012	---	
			Y	CFRETFE	SMF0013	---	
			T	CFRETFE	---	SMF0055	
			X	CFRETFE	---	SMF0098	
	Impeller UNIT (for KK)	Impeller code	V	CFRETFE	SMF0014	---	
			Y	CFRETFE	SMF0015	---	
			T	CFRETFE	---	SMF0056	
			X	CFRETFE	---	SMF0099	
11	Magnet capsule UNIT		CF	---	SMF0017	SMF0058	
			RF	---	SMF0018	SMF0059	
			KK	---	SMF0019	SMF0060	
19	Flange		CFRETFE	SMF0031			
26.1	Rear thrust ring (for RF)		Alumina ceramic	SMF0037			
26.2	Rear thrust	For CF•KK		CFRETFE	SMF0038		
		For RF		CFRETFE	SMF0039		
27	Spindle	For CF•RF		Alumina ceramic	SMF0040		
		For KK		SiC	SMF0041		
		V	FKM	SMF0042			
30	Gasket		E	EPDM	SMF0043		
			V	FKM	SMF0044		
31.1	O ring (for Rear casing)		E	EPDM	SMF0045		
			V	FKM	SMF0046		
31.2	O ring (for Drain cap/ Flange)		E	EPDM	SMF0047		
			V	FKM	SMF0048		
31.3	O ring (for Rear case)		E	EPDM	SMF0064		
			V	FKM	SMF0050		
31.4	O ring (for Cap)		E	EPDM	SMF0051		

Maintenance

(SMX-F44)

No	Part names		Material	Part code			
				SMX-F441	SMX-F442	SMX-F443	
1	Front case		CFRETFE	SMF0072			
2	Rear case (for CF•RF)		CFRETFE	SMF0073			
	Rear case (for KK)		CFRETFE	SMF0074			
3	Rear casing		CFRETFE	SMF0006			
4	Volute spacer	Impeller code	T	CFRETFE	SMF0075	—	
			Y	CFRETFE	SMF0076	—	
			X	CFRETFE	—	SMF0092	
6	Plate		CFRETFE	SMF0077			
7	Cap		CFRETFE	SMF0010			
8	Drain cap		CFRETFE	SMF0011			
9+29	Impeller UNIT (for CF•RF)	Impeller code	T	CFRETFE	SMF0080	—	
			Y	CFRETFE	SMF0079	—	
			X	CFRETFE	—	SMF0093	
	Impeller UNIT (for KK)	Impeller code	T	CFRETFE	SMF0080	—	
			Y	CFRETFE	SMF0081	—	
			X	CFRETFE	—	SMF0094	
11	Magnet capsule UNIT		CF	—	SMF0058	SMF0066	
			RF	—	SMF0059	SMF0067	
			KK	—	SMF0060	SMF0068	
19	Flange		CFRETFE	SMF0085			
26.1	Rear thrust ring (for RF)		Alumina ceramic	SMF0037			
26.2	Rear thrust	for CF•KK		CFRETFE	SMF0038		
		for RF		CFRETFE	SMF0039		
27	Spindle	for CF•RF		Alumina ceramic	SMF0040		
		for KK		SiC	SMF0041		
30	Gasket		V	FKM	SMF0086		
			E	EPDM	SMF0087		
31.1	O ring (for Rear casing)		V	FKM	SMF0044		
			E	EPDM	SMF0045		
31.2	O ring (for Drain cap)		V	FKM	SMF0046		
			E	EPDM	SMF0047		
31.3	O ring (for Rear case)		V	FKM	SMF0088		
			E	EPDM	SMF0089		
31.4	O ring (for Cap)		V	FKM	SMF0050		
			E	EPDM	SMF0051		
31.5	O ring (for Flange)		V	FKM	SMF0090		
			E	EPDM	SMF0091		

Maintenance

(SMX-F54)

No	Part names		Material	Part code			
				SMX-F542	SMX-F543	SMX-F545	
1+6.2	Front case UNIT		CFRETFE	SMF0163			
2	Rear case (for CF•RF)		CFRETFE	SMF0107			
	Rear case (for KK)		CFRETFE	SMF0108			
3	Rear casing		CFRETFE	SMF0109			
4	Volute spacer	Impeller code	Z	CFRETFE	—	SMF0143	
			V	CFRETFE	SMF0110		
			T	CFRETFE	—	—	SMF0110
			Y	CFRETFE	SMF0144		
			X	CFRETFE	—	—	SMF0144
6.1	Plate		CFRETFE	SMF0111			
7	Cap		CFRETFE	SMF0010			
8	Drain cap		CFRETFE	SMF0011			
9+29	Impeller UNIT (for CF•RF)	Impeller code	Z	CFRETFE	—	SMF0145	
			V	CFRETFE	SMF0113		
			Y	CFRETFE	—	—	SMF0113
			T	CFRETFE	SMF0146		
			X	CFRETFE	—	—	SMF0146
	Impeller UNIT (for KK)	Impeller code	Z	CFRETFE	—	SMF0147	
			V	CFRETFE	SMF0114		
			Y	CFRETFE	—	—	SMF0114
			T	CFRETFE	SMF0148		
			X	CFRETFE	—	—	SMF0148
11.1	Magnet capsule UNIT		CF	—	SMF0115	SMF0149	
			RF	—	SMF0116	SMF0150	
			KK	—	SMF0117	SMF0151	
11.2	Lock pin		CFRETFE	SMF0118			
19.1	Flange 40A		CFRETFE	SMF0085			
19.2	Flange 50A		CFRETFE	SMF0119			
26	Rear thrust	for CF•RF	Alumina ceramic	SMF0120			
		for KK	SiC	SMF0121			
27	Spindle	for CF•RF	Alumina ceramic	SMF0122			
		for KK	SiC	SMF0123			
30	Gasket		V	FKM	SMF0124		
			E	EPDM	SMF0125		
31.1	O ring (for Rear casing)		V	FKM	SMF0126		
			E	EPDM	SMF0127		
31.2	O ring (for Drain cap)		V	FKM	SMF0046		
			E	EPDM	SMF0047		
31.3	O ring (for Rear case)		V	FKM	SMF0128		
			E	EPDM	SMF0129		
31.4	O ring (for Cap)		V	FKM	SMF0050		
			E	EPDM	SMF0051		
31.5	O ring (for Flange 40A)		V	FKM	SMF0090		
			E	EPDM	SMF0091		
31.6	O ring (for Flange 50A)		V	FKM	SMF0130		
			E	EPDM	SMF0131		

Maintenance

4. Disassembly & Assembly

See this exploded view when dismantling/assembling the pump. Do not dismantle the pump beyond the extent of instructions in this manual.

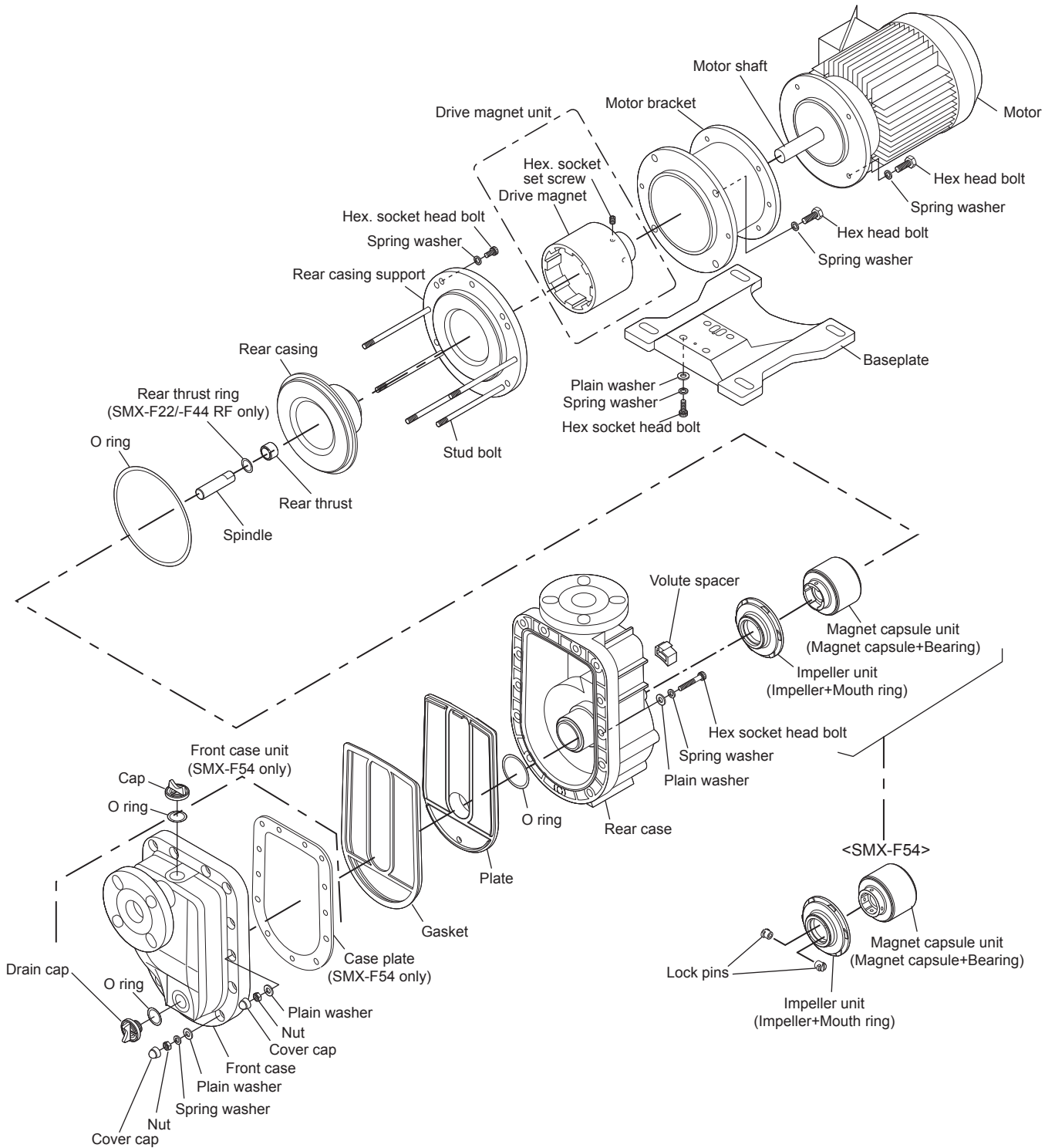

Maintenance

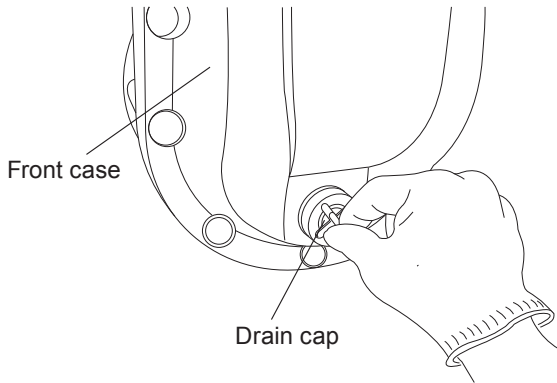

■ Dismantlement

1. Remove the drain cap and drain liquid from the pump unit. (Liquid can not be drained completely. Some liquid remains in the pump unit.)

NOTE: Do not open the drain cap fully at once. Otherwise liquid may blow out.

⚠ CAUTION

Wear chemical proof gloves for the prevention of getting wet with a chemical. Do not drain a chemical onto a floor. Always collect it in a suitable container.

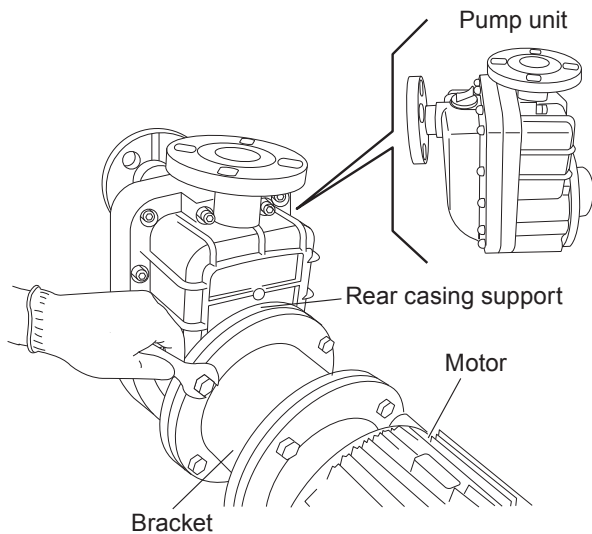

2. Loosen four hex. head bolts on the motor bracket and pull out the pump unit straight from the motor. Drain residual liquid from the pump unit after detachment.

NOTE: Do not tilt the unit to the axis, or the unit may be stuck in the bracket. Push it back into the bracket and try again once it has been stuck.

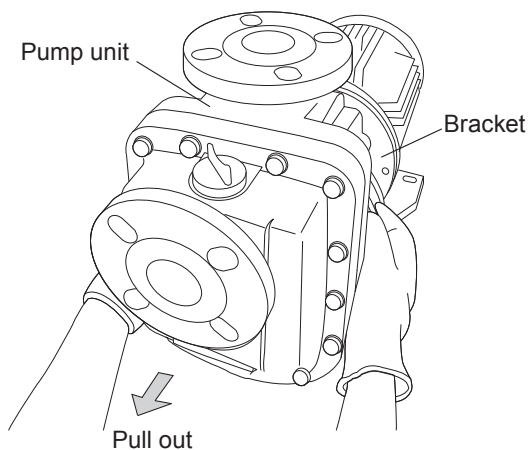

⚠ CAUTION

There is strong magnetic force between the pump unit and motor and both parts are attracted each other. Be careful not to catch the finger. Do not remove the bracket from the motor.

Maintenance

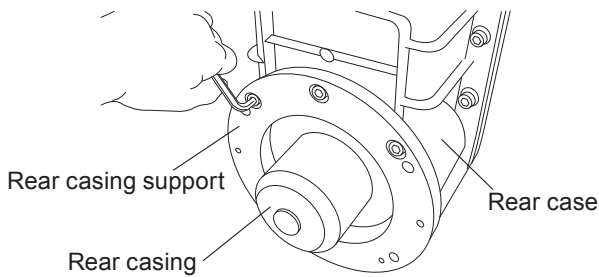

3. Remove three hex. socket head bolts which are fixing the rear casing support to rear case.

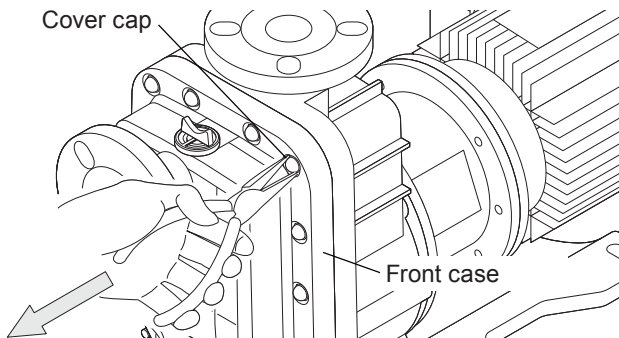

4. Remove all cover caps by using nippers.
NOTE: Pinch the cylindrical body of the cap and pull it straight.

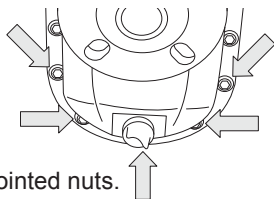

Remove these pointed nuts.

5. Loosen the five nuts on the front case (pointed by arrows).

CAUTION

Be careful. Residual liquid can start to leak at this point.

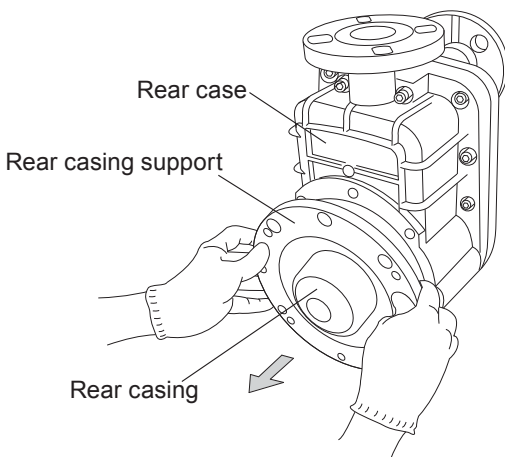

6. Pull out the rear casing support with stud bolts on it.

7. Remove the rear casing and the combination of the impeller & magnet capsule units.

NOTE: Do not drop the impeller & magnet capsule units from the rear casing.

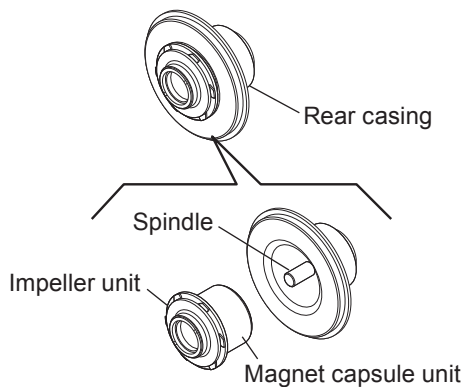

8. Pull out straight the combination of the impeller & magnet capsule units from the rear casing.

NOTE: Do not separate the both units when removing from the casing.

Maintenance

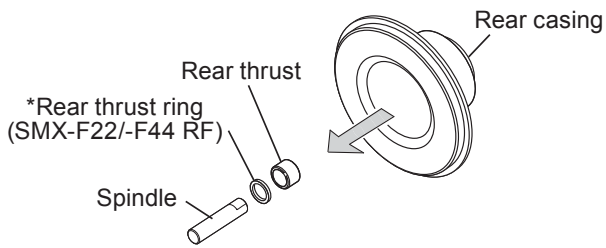

9. Immerse the rear casing in hot water for five minutes in order to soften it. And then remove a spindle and a rear thrust.

NOTE: A rear thrust ring is attached only to the SMX-F22/-F44 RF type. Do not forget to attach it.

! CAUTION

Be careful not to burn yourself.

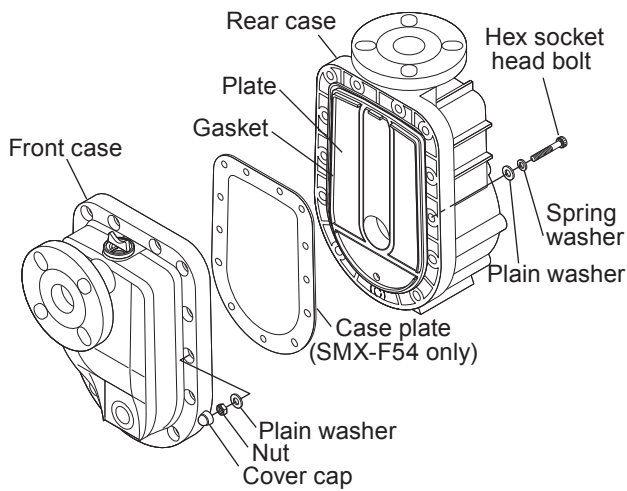

10. Loosen all hex. socket head bolts from the front case and separate the front case and rear case.

NOTE: Remove a case plate for the SMX-F54.

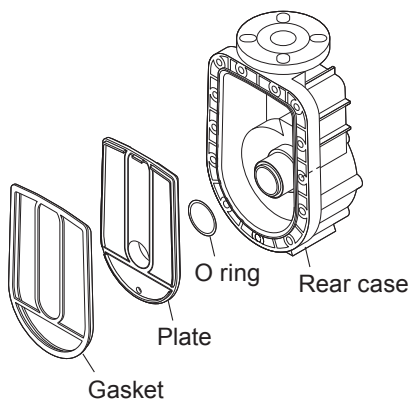

11. Remove a plate, a gasket and an O ring.

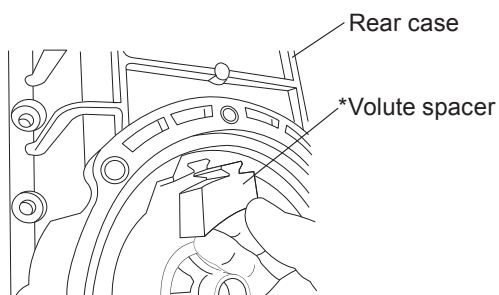

12. Remove a volute spacer (if necessary).

NOTE: The volute spacer is placed for efficient degassing and contributes to faster self priming completion. Keep it in place.

Maintenance

■ Assembly

! INSPECTION

If foreign matters such as iron powder stay on the magnet capsule by magnetic force, remove them.

! CAUTION

Check that the O ring and gasket grooves are free from dust and scratches. Use new parts as necessary.

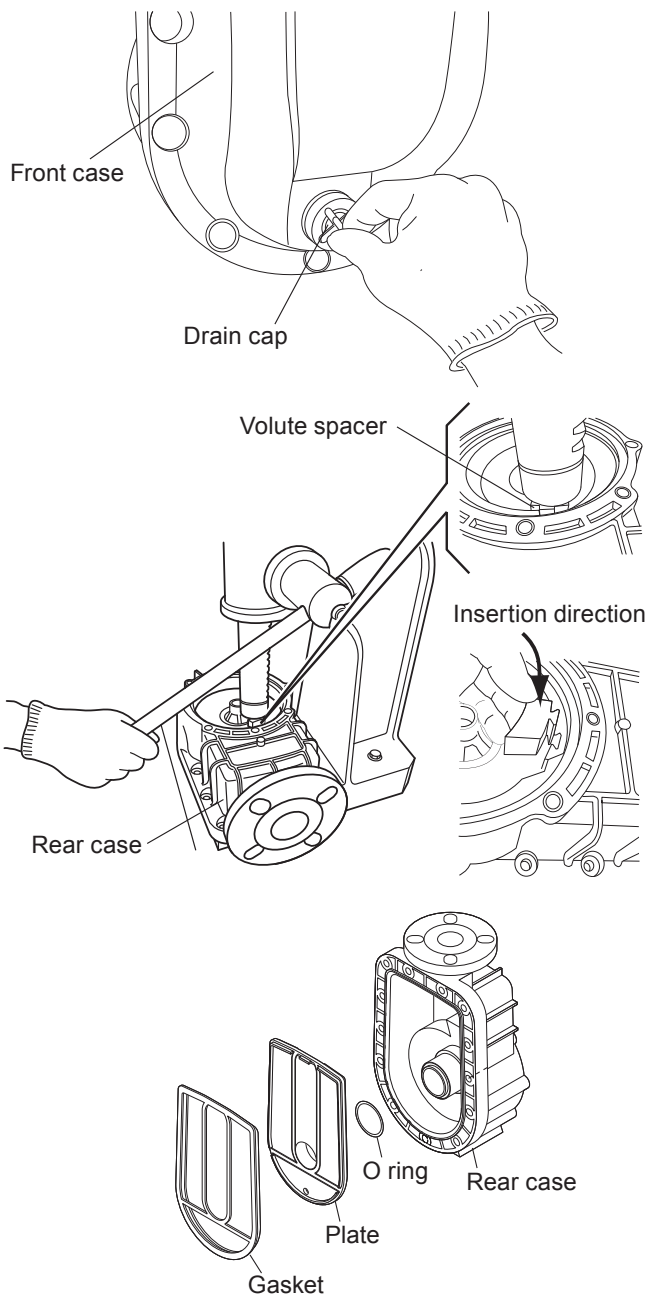

1. Fit an O ring to the drain cap and screw the cap into the drain port on the front case.

2. Press fit the volute spacer by a handpress if it was detached. Pay attention to an insertion direction.

3. Fit a gasket to the plate (Make sure the gasket is completely fitted in the groove.).

4. Mount the O ring and the plate to the rear case.

Maintenance

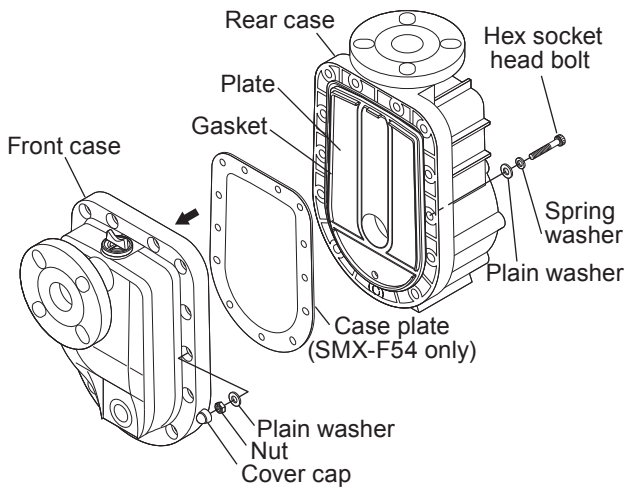

- Combine the front case, rear case and case plate (SMX-F54 only), and temporarily tighten them by the hex. socket head bolts for preventing O ring and plate from moving.

NOTE: Fit the case plate into the front case, and then combine the front case and the rear case while holding the front case.

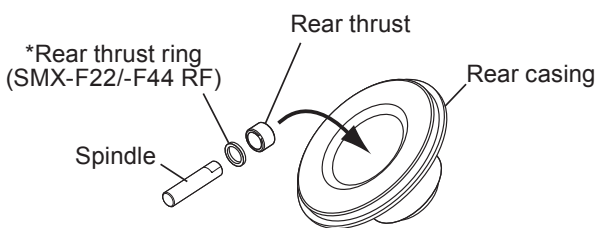

- Insert the rear thrust to the spindle end. And then fit the spindle to the rear casing by hand, mating joint surfaces.

NOTE: A rear thrust ring is attached only to the SMX-F22/-F44 RF type. Do not forget to attach it.

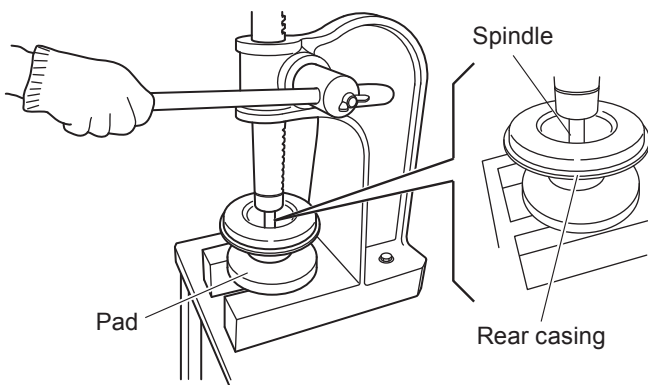

- Press the spindle into the rear casing by a handpress.
- NOTE:** Keep the spindle upright during insertion.

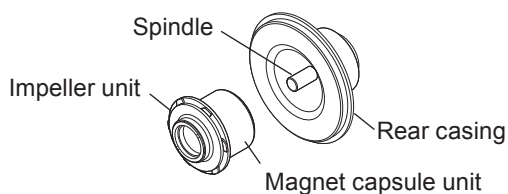

- Combine the impeller and magnet capsule units (See page 42 & 45 for impeller unit mounting.) and insert the combination into the rear casing via the spindle.

Maintenance

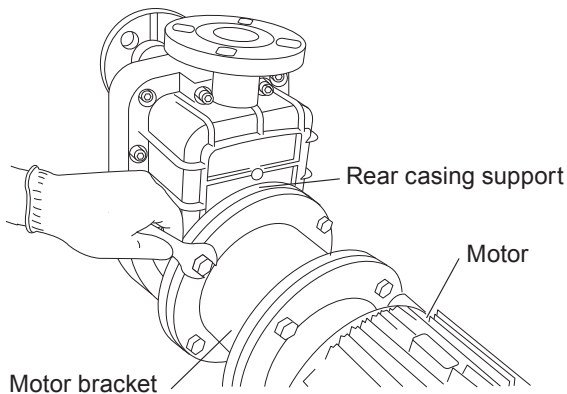
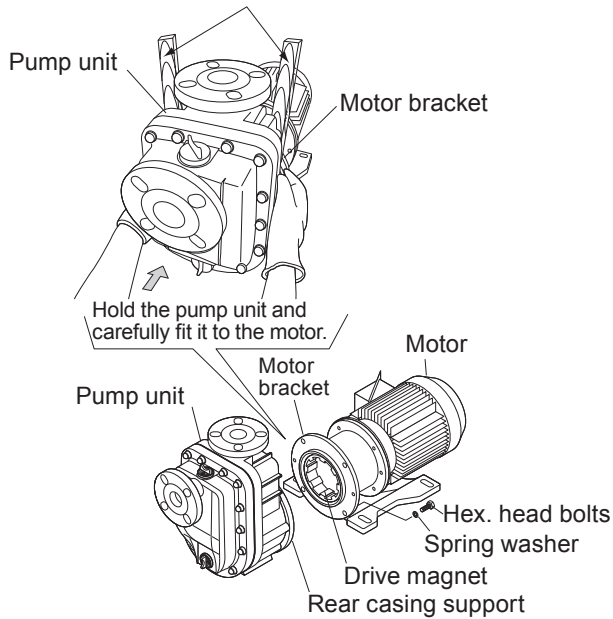
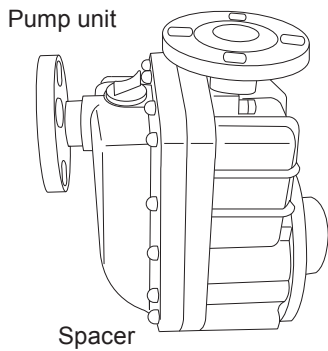
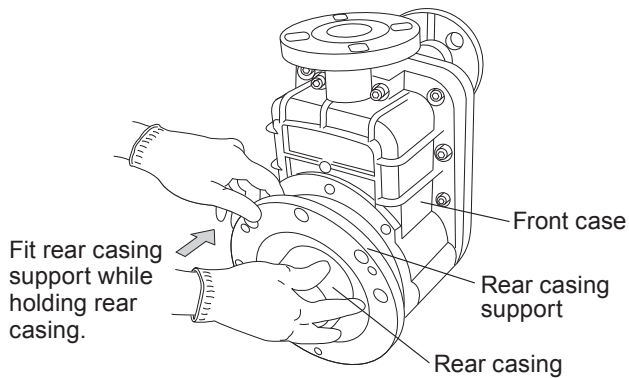

9. Fit the rear casing support while holding the rear casing on the rear case. Temporarily tighten three hex. socket head bolts on the rear casing support and five stud bolts.

10. Tighten all bolts on tightening torque below. Attach cover caps afterwards.

⚠ CAUTION

Stainless bolts/nuts are easy to be galled.

Tightening torque

Bolt size	Tightening torque
M8	11.8 N•m
M10	14.7 N•m

11. Apply spacers between the pump unit and motor bracket to secure a space for preventing the finger from being caught. Carefully place the pump unit in the motor bracket while holding the pump unit.

⚠ CAUTION

Be careful not to catch the finger between the motor bracket and the pump unit. The pump unit is attracted to the motor by magnet force. Fix the motor for preventing it from moving toward the pump unit.

12. Tighten four hex. head bolts on the motor bracket in order to combine the motor and the pump unit.

Maintenance

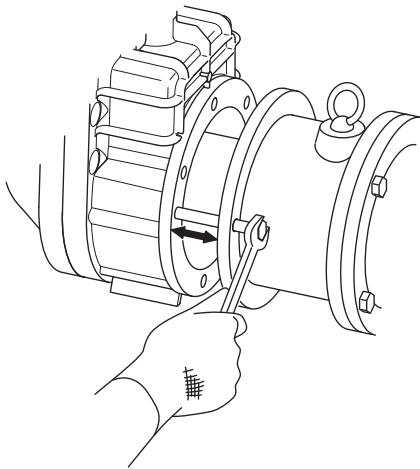

NOTE: Screw two M10×50 bolts into the bracket holes until they come out about 45mm forward, mating the screw ends with the holes on rear casing support. Then start screwing down the bolts evenly in order to move the pump unit closer to the motor and finally put these components together. Reverse this procedure when removing the pump unit. Be careful not to catch the finger in the unit. There is strong magnetic force between them.

For the SMX-F54, use the attached back pullout bolts. For other models, purchase two M10×50 bolts separately.

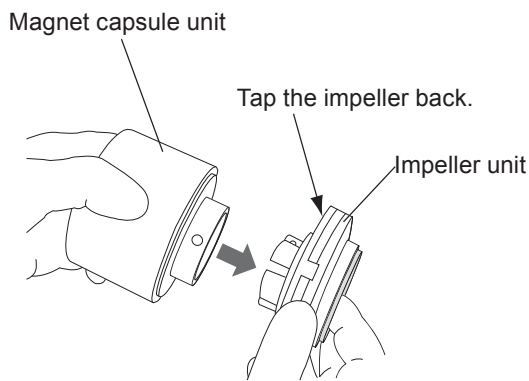

■ Impeller unit removal (SMX-F22/-F44)

1. Immerse and warm the combination of the impeller and magnet capsule units in hot water of 90°C for five minutes.
2. Tap the back side of the impeller by a plastic hammer to detach it.

⚠ CAUTION

Be careful not to get scalded with hot water.

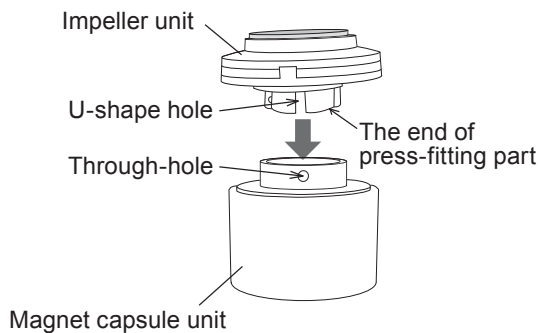

■ Impeller unit mounting (SMX-F22/-F44)

1. Immerse and warm the magnet capsule unit in hot water of 90°C for five minutes.

NOTE: If the impeller unit is hardly fitted to the magnet capsule unit, always warm the magnet capsule unit in hot water for softening.

Maintenance

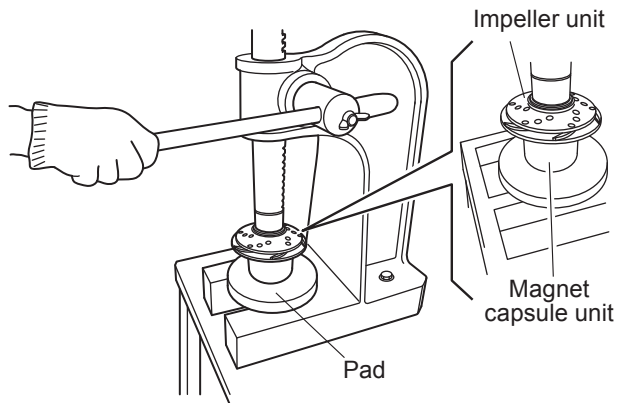

2. Press the impeller unit into the magnet capsule unit by a handpress. At this time make sure that the through-holes on the magnet capsule comes under the U-shape holes of the impeller unit.

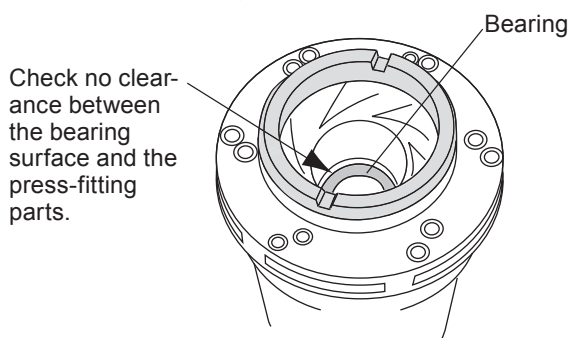

NOTE: Check that the end of press-fitting parts has come at a bearing surface.

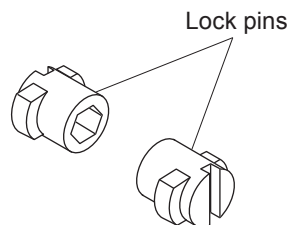

Lock pins are inserted from the inside of the magnet capsule assembly to catch the impeller unit.

■ Impeller unit removal (SMX-F54)

The impeller unit can not be separated from the magnet capsule assembly unless the lock pins are removed.

The mating surface on the magnet capsule assembly has two holes. The large hole (6mm dia) is for the lock pins and the small hole (3mm dia.) is for cooling. To attach the impeller unit to the magnet capsule assembly, press the unit into the assembly with U-shape hole under the smaller hole (3 mm dia.).

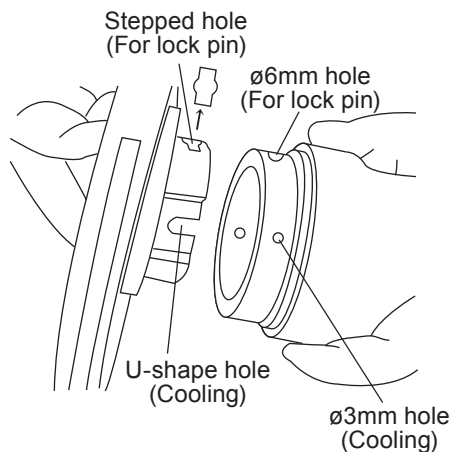

Maintenance

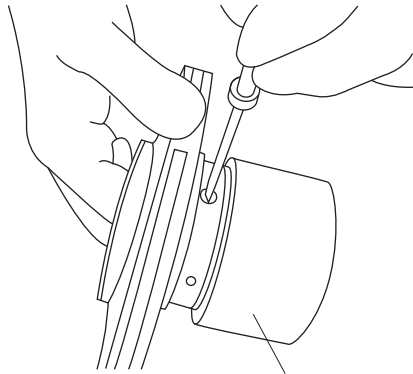

Magnet capsule unit

1. Turn the lock pins 90 degrees anticlockwise using a flathead screwdriver and then push them off. Slightly tap the end of driver handle to make it easier.

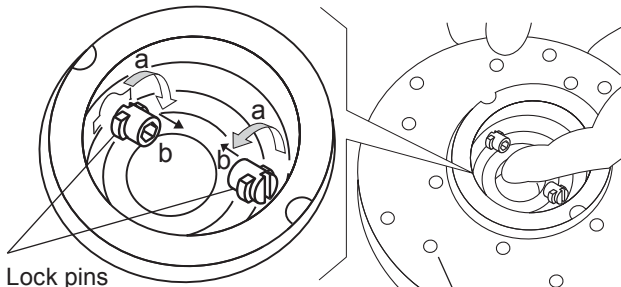

Lock pins

- a. Rotate in the direction of an arrow.
- b. Push off inwards.

Impeller unit

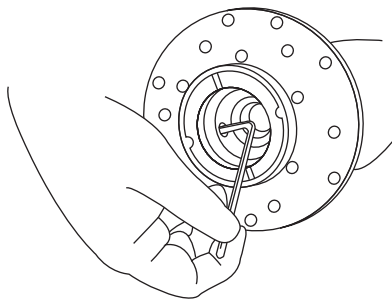

2. The lock pins can also be turned by using the 4mm hex. wrench from the inside of magnet capsule assembly. Turn the wrench 90 degrees in the direction of an arrow. Then push the pins off from the outside by using a bar.

NOTE: Always turn the lock pins in a correct direction, or the lock pins may be damaged.

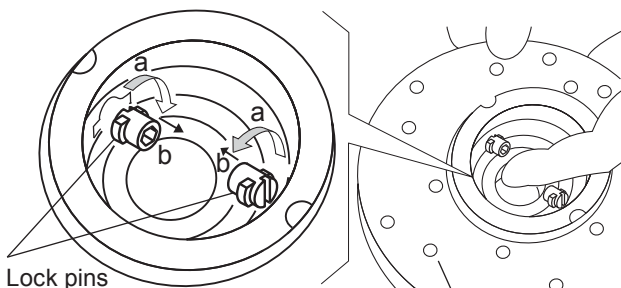

Lock pins

- a. Rotate in the direction of an arrow.
- b. Push off inwards.

Impeller unit

Maintenance

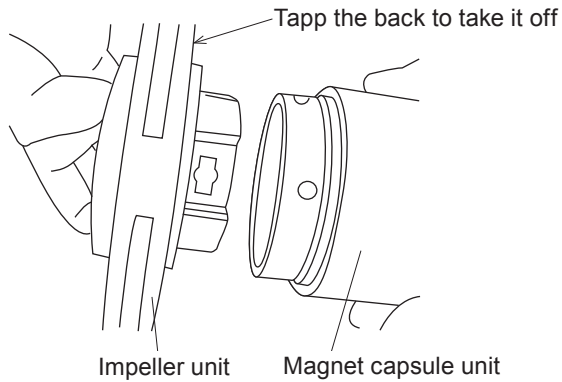

3. After the lock pins are removed, detach the impeller unit from the magnet capsule assembly by slightly tapping the back of the impeller unit with a plastic hammer.

NOTE: If the impeller unit is hardly removed, warm it in hot water (approx. 90°C) for 5 minutes and tap it slightly, again.

CAUTION

Be careful not to get scalded with hot water.

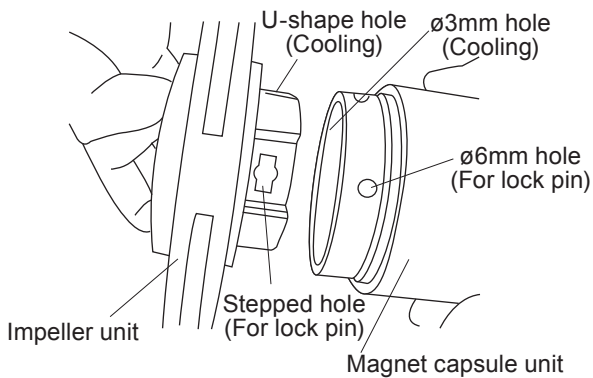

■ Impeller unit mounting (SMX-F54)

1. Press and fit the impeller unit into the magnet capsule assembly with the stepped holes under the large holes (6mm dia.).

NOTE: If the impeller unit is hardly fitted to the magnet capsule assembly, warm it in hot water (about 90°C for 5 minutes) for softening.

CAUTION

Be careful not to get scalded with hot water.

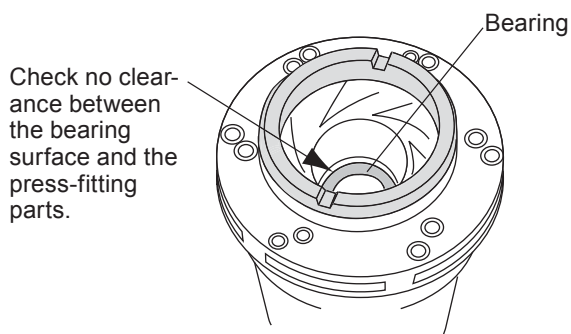

Maintenance

2. After fitting the impeller unit, push the lock pins into the lock pin holes from the inside as far as it will go. Use a flat-head screwdriver to turn the pins 90 degrees clockwise from the outside while holding the pins from the inside. Once it clicks, the impeller unit is secured.

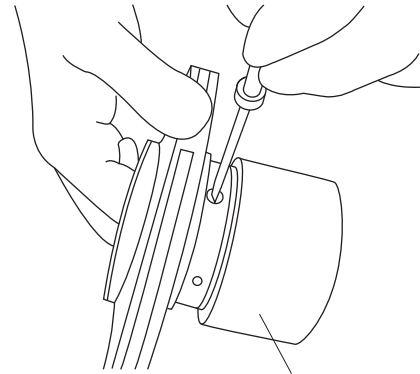

Magnet capsule unit

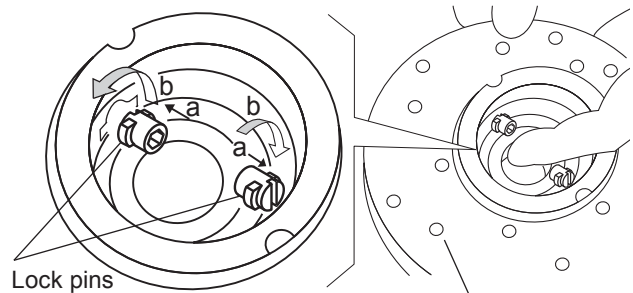

Lock pins

- a. Push outwards.
b. Rotate by 90° in the direction of an arrow.

Impeller unit

3. The lock pins can also be turned by using the 4mm hex. wrench from the inside of magnet capsule assembly. Push the pins into the lock pin holes from the inside and turn the wrench 90 degrees in the direction of an arrow until it clicks.

NOTE: Always turn the the lock pins in a correct direction, or the lock pins may be damaged.

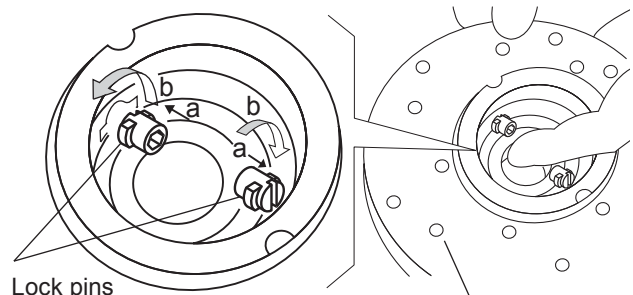
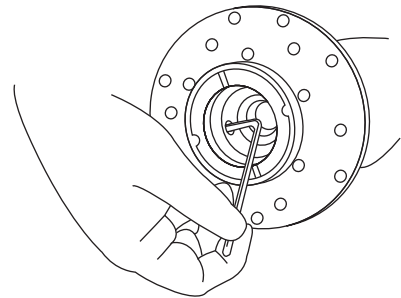

Lock pins

- a. Push outwards.
b. Rotate by 90° in the direction of an arrow.

Impeller unit



()Country codes
IWAKI CO.,LTD. 6-6 Kanda-Sudacho 2-chome Chiyoda-ku Tokyo 101-8558 Japan
 TEL:(81)3 3254 2935 FAX:3 3252 8892(<http://www.iwakupumps.jp>)

Australia	IWAKI Pumps Australia Pty. Ltd.	TEL: (61)2 9899 2411	FAX: 2 9899 2421	Italy	IWAKI Italia S.R.L.	TEL: (39)02 990 3931	FAX: 02 990 42888
Austria	IWAKI (Austria) GmbH	TEL: (43)2236 33469	FAX: 2236 33469	Korea	IWAKI Korea Co.,Ltd.	TEL: (82)2 2630 4800	FAX: 2 2630 4801
Belgium	IWAKI Belgium n.v.	TEL: (32)1367 0200	FAX: 1367 2030	Malaysia	IWAKIm Sdn. Bhd.	TEL: (60)3 7803 8807	FAX: 3 7803 4800
China	IWAKI Pumps (Shanghai) Co., Ltd.	TEL: (86)21 6272 7502	FAX: 21 6272 6929	Norway	IWAKI Norge AS	TEL: (47)66 81 1660	FAX: 66 81 1661
China	IWAKI Pumps (Guandong) Co., Ltd.	TEL: (86)750 3866228	FAX: 750 3866278	Singapore	IWAKI Singapore Pte. Ltd.	TEL: (65)6316 2028	FAX: 6316 3221
China	GFTZIWAKI Engineering & Trading (Guangzhou)	TEL: (86)20 8435 0603	FAX: 20 8435 9181	Spain	IWAKI Iberica Pumps, S.A.	TEL: (34)943 630030	FAX: 943 628799
China	GFTZIWAKI Engineering & Trading (Beijing)	TEL: (86)10 6442 7713	FAX: 10 6442 7712	Sweden	IWAKI Sverige AB	TEL: (46)8 511 72900	FAX: 8 511 72922
Denmark	IWAKI Nordic A/S	TEL: (45)48 24 2345	FAX: 48 24 2346	Switzerland	IWAKI (Schweiz) AG	TEL: (41)26 674 9300	FAX: 26 674 9302
Finland	IWAKI Suomi Oy	TEL: (358)9 2745810	FAX: 9 2742715	Taiwan	IWAKI Pumps Taiwan Co., Ltd.	TEL: (886)2 8227 6900	FAX: 2 8227 6818
France	IWAKI France S.A.	TEL: (33)1 69 63 33 70	FAX: 1 64 49 92 73	Taiwan	IWAKI Pumps Taiwan (Hsin-chu) Co., Ltd.	TEL: (886)3 573 5797	FAX: (886)3 573 5798
Germany	IWAKI EUROPE GmbH	TEL: (49)2154 9254 0	FAX: 2154 9254 48	Thailand	IWAKI (Thailand) Co., Ltd.	TEL: (66)2 322 2471	FAX: 2 322 2477
Holland	IWAKI EUROPE NL Branch	TEL: (31)547 293 160	FAX: 547 292 332	U.K.	IWAKI Pumps (UK) LTD.	TEL: (44)1743 231363	FAX: 1743 366507
Hong Kong	IWAKI Pumps Co., Ltd.	TEL: (852)2 607 1168	FAX: 2 607 1000	U.S.A.	IWAKI AMERICA Inc.	TEL: (1)508 429 1440	FAX: 508 429 1386
Indonesia	IWAKI Singapore (Indonesia Branch)	TEL: (62)21 690 6606	FAX: 21 690 6612	Vietnam	IWAKI pumps Vietnam Co.,Ltd.	TEL: (84)613 933456	FAX: 613 933399