

IWAKI
METERING
PUMPS



Applicable to the many diverse needs of chemical feeding

Iwaki's systematic LK series metering pump consists of the worm gear type dual-cam driving section, which is compact yet rigid and reliable, and wet-end materials of which there are seven types for various applications.

With long and market-proven experience, Iwaki has employed state-of-the-art pump technologies in the development of an ideal type of chemical feeding pump which has advantages such as quality, performance, ease of operation and cost efficiency.

The LK series is suitable for many chemical liquid feeding processes used in a wide range of fields, including water treatment, chemicals, fabrics, paper mill, food processing, and medicine.

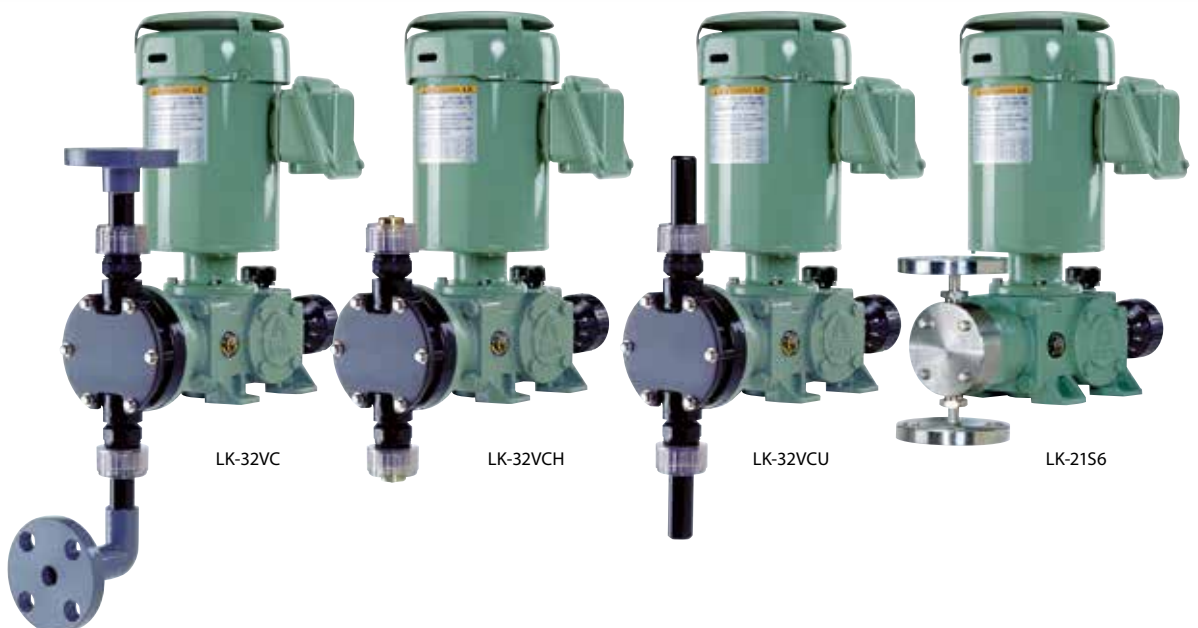
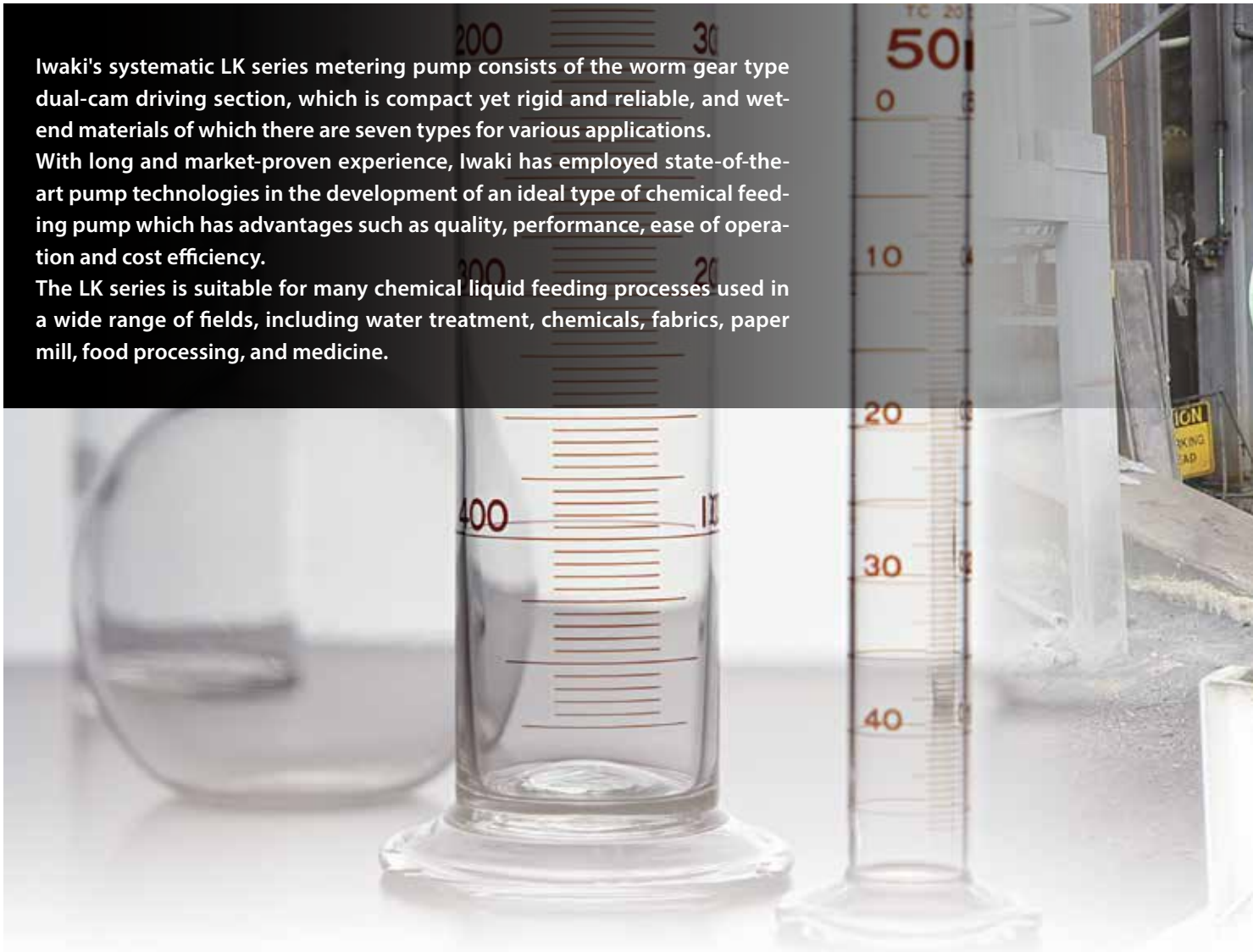

LK-32VC

LK-32VCH

LK-32VCU

LK-21S6



Various types and materials

Nine types (IWAKI original motor) and eight general purpose motor types are available to suit each user's needs in accordance with feeding rate from small to large capacity. Also, material variation has been improved. Selection of the pump material most suitable for the applied liquid is possible with seven different types available.

High performance and application-oriented versatile design

Discharge accuracy (stability) is within $\pm 2\%$ FS. Reliability is considerably enhanced through efforts to improve the linearity of the stroke / discharge ratio as well as the dispersion between stroke.

Three types of joints flange, hose and union joints are standardized for the connections. The optimum piping system can be selected. (Only with 0.2kW IWAKI original motor type)



LK-B75S4



LK-B65VC



LK-C86VC

Construction

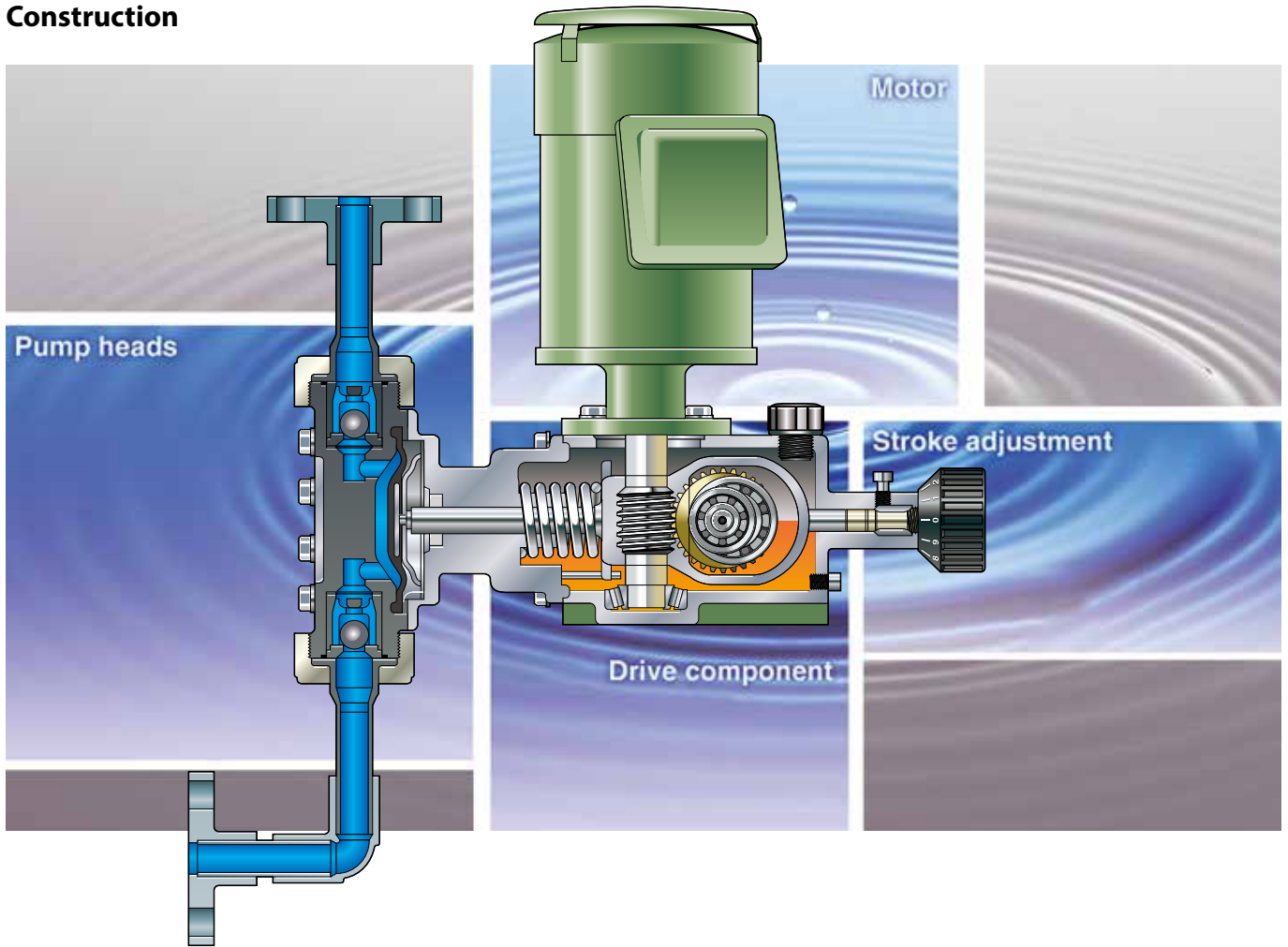

Pump heads

Drive from the gear reduction unit is directly transmitted to the diaphragm. This type of metering pump is economical and simple with a high degree of versatility. With the employment of moulded PVC pump-head, and with the new standardisation of three types of connections using flanges, hose, or union joints (0.2kW type), not only a saving in parts cost but also improved flexibility of installation has been realized. The three main pump head materials are PVC, stainless steel, or fluororesin. The most suitable type for the application can be selected from a total of seven different materials. A wide range of chemicals, such as acid, alkaline, organic solvent, slurry, and high-temperature liquids, is covered by the series.

• Please contact us for Model PVDF.

Drive component

The head of the LK series is the dual-cam system driving section with a highly reliable, built-in worm gear type speed reducer. The compact and rigid mechanism is a result of the design goal to achieve maximum wear resistance in continuous operation. In addition to the worm gear which is designed with a considerably large module ratio, the material is aluminium bronze, and a taper roller bearing is used at the end of the worm gear for the efficient transmission of motor power to the pump section. A fully enclosed oil bath lubrication system is employed to permit outdoor installation. The durability in continuous operation over a long period of time is also excellent.



Motor

All of the standard models employ totally enclosed outdoor-use motors which are vertically mounted to save space. The 0.2kW type is an IWAKI original motor, which is installed in the small models of the LK series. Besides the standard 200V, other voltages are available. The LK series pumps of LK-F, LK-A, LK-B, and LK-C can be installed with general-purpose motors, including those for different voltage levels and explosion-proof specifications. Body configurations of the LK series are available in five types. They are an IWAKI original motor type frame and the general-purpose motor type frames, F, A, B and C.

Stroke adjustment

Accurate and reliable stroke setting is possible with the micrometer type dial of the springback type stroke adjustment mechanism. An electric servo unit for automatic process control, such as flow, pressure, pH, temperature, and concentration can be arranged according to the user's needs.

Electric servo system Specifications

- **Input signal :**
DC4 - 20mA (or 1 - 5V)
- **Power source :**
AC100V 50/60Hz; other voltage types available
Voltage fluctuation 10%
- **Motor output :**
LK (0.2kW) 15W
LK-A, B, C 40W

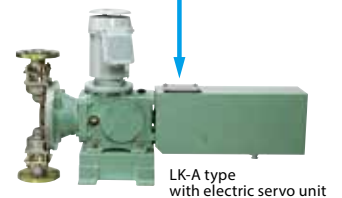
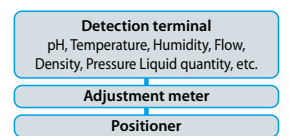

Specifications

Model	Capacity L/min		Max. Pressure MPa		Stroke speed spm		Effective diaphragm dia. ømm	Max. stroke length mm	Connection ^{Note 3}			Motor output kW ^{Note 4}	Approx net weight kg ^{Note 5}						
	^{Note 1}		^{Note 2}		50Hz	60Hz			Flange (JIS10K)	Union	Hose ømm		PVC	SUS					
	50Hz	60Hz	PVC	SUS															
LK-11	0.020	0.024	1.0	1.5	48	58	22	1.5	15A (PVC)	VP16 (PVC)	4 x 9 (PVC)	0.2 (Three phase) or 0.25 (Single phase)	12	14					
21	0.050	0.060			96	116	30								2.0				
22	0.10	0.12			48	58	60								2.5				
31	0.25	0.30			96	116													
32	0.50	0.60			48	58													
45	0.85	1.00			96	116	100								10				
47	1.7	2.0			0.8	96										116			
55	2.8	3.3			0.5	48										58			
57	6.0	7.2			0.3	96	116								25A	VP25 (PVC)	-	16	26
LK-A55	2.8	3.3			1.0	48	58								100	10	25A	-	-
A57	6.0	7.2	0.7	96	116	138	17.5	40A	-	-	0.75	100	100						
A65	9.0	10.8	0.3	48	58														
B65	9.0	10.8	0.5	0.7	48									58					
B75	13.3	16.0	0.5	72	86	150	20	50A	-	-	1.5	105	105						
C76	20	24	0.5			150	50A	120				120							
C86	33	40	0.3			205	20	65A				-	-	140	155				
C87	45	54	0.3	96	116														

- Note 1: The capacity is the value when maximum discharge pressure is applied (with pure water at room temperature). The value may be larger than indicated in the table if the discharge pressure is lower. As for the liquid conditions pumped and performance, refer to the technical information of this catalogue.
- Note 2: The maximum discharge pressure of LK-A models are restricted to 0.7MPa for A55, 0.5MPa for A57 and 0.2MPa for A65 when IEC standard 0.37kW motor is adopted.
- Note 3: VS type connection is different in some models from standard.
- Note 4: The LK type is equipped with Iwaki original flange motor. The standard is 200V 3-phase, totally enclosed fan-cooled outdoor type. Other motors for different voltages, explosion-proof motors, or single-phase motors are available. LK-F, LK-A, B and C are to be installed with general purpose flange motors.
- Note 5: The weight is the value when installed with a totally enclosed fan-cooled outdoor motor.
- Standard accessory : A siphon preventing valve, strainer and 4m PVC tube are furnished to hose connection type of simplex LK-11 to LK-45 VH or VC A base is furnished to all LK-A, LK-B and LK-C models. For LK-(F) 11 to LK-(F) 57 models, the base may be supplied optionally.
- Coating color : F37-60D (JPMA) (However, the motors for LK-F/A/B/C use the maker's standard color.)
- Duplex type : LK-11 to 47 type include duplex types with a special-use integrated drive section.

Materials

LK-11 to LK-57 (Flange type)

LK-A55 to LK-C87 (Flange type)

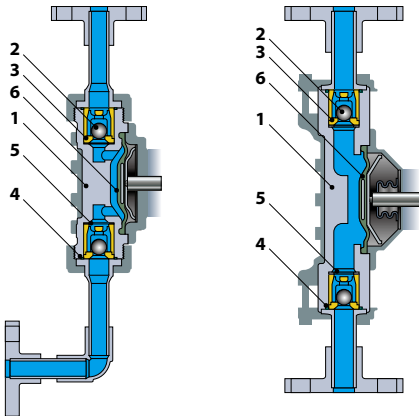

Type	VC	VH	VS4	VS	S6	S4	
Application	Acids	Alkalines		Viscosity and Slurry	Solvents		
Applicable type	11 to 87	11 to A57	A65 to C87	11 to C87	11 to A57	A65 to C87	
1: Pump head	PVC					SUS316	SCS13
2: Valve ball	CE	HC	SUS304	HC / SUS304	HC	SUS304	
3: Valve seat	FKM	EPDM	PVC	SUS304	SUS316	SUS304	
4: O ring	FKM	EPDM		SUS304	SUS316	SUS304	
5: Valve gasket	PTFE				PTFE		
6: Diaphragm	PTFE + EPDM						
Typical chemical			Material symbols				
VC: Sulfuric acid, Hydrochloric acid, Sodium hypochlorite			SCS13: Stainless-cast steel equivalent to SUS304				
VH, VS4: Caustic soda, Coagulant. Calcium hydroxide (low density)			CE: Ceramic				
VS: Calcium hydroxide, Highmolecular coagulant			FKM: Fluoro rubber				
S6, S4: Organic solvent, Paper making chemicals			EPDM: Ethylene propylene rubber				
			HC: Hastelloy C276				

- Materials of the VS type valve balls are HC for 11 to A57 type and SUS304 for B65 to C87 type. As for the connection, which is different in some models from standard.
- A stainless steel pump SE type for latex emulsion is available (LK-31 to 57 type).
- Material PVdF is also available. Please contact us for details.

Pump identification

2 LK - A 65 VC H - 04 F E S

- Simplex / Duplex**
LK (IWAKI original motor type)
None: Simplex
2: Duplex (special drive section:LK-11 to 47)
LK-F/A/B/C (JEM or IEC motor type)
None: Simplex
- Series name**
L series : Mechanical driven diaphragm type
- Drive section**
LK (IWAKI original motor type)
None : IWAKI original motor type 0.2kW / 0.25kW
LK-F/A/B/C (JEM or IEC motor type)
F: 0.25 or 0.37 kW (for IEC), 0.4kW
A: 0.4kW
B: 0.75kW
C: 1.5kW
- Type No.**
First digit : Diaphragm (pump head size)
Second digit : Speed-reducing gear ratio 1-5 : 1/30, 2-7 : 1/15, 6 : 1/20
- Material symbol**
Refer to the material table (Ex. VC, VH, VS4, VS, S6, S4)
- Motor output**
LK (IWAKI original motor type)
02: 0.2kW, 03: 0.25kW (single phase)
LK-F/A/B/C (JEM or IEC motor type)
04: 0.4kW, 07: 0.75kW, 15: 1.5kW
- Special symbol**
S: Special specification other than standard.
- Servo unit**
E: With electric servo unit
- Special motor**
LK-F/A/B/C (JEM or IEC motor type)
F: Inverter motor
(Note : General-purpose motors have no explosion-proof symbol.)
- Joint**
None : Flange
U: union (LK-11 to LK-57)
H: hose (LK-11 to LK-47)

• This table does not introduce the standard combination. Please contact us for details.
• In case of pump without motor installation, the above item 7 and 8 are not indicated.

Points to be observed in pump installation and piping

Iwaki metering pump LK series are reciprocating pumps employing the eccentric cam system.

Reciprocating pumps generate pulsation in the suction and discharge piping. Special consideration, (different from the ordinary centrifugal pumps), should be given to this point when planning the pump installation and piping.

• Prevention of pipe vibration

Discharge side inertial resistance $P_{id} < 0.1 \text{ MPa}$
 • P_{id} : Inertial resistance on discharge side

Inertial resistance means the pulsed impact force generated by the flow just upon entering discharge stroke. It is a phenomenon particular to a reciprocating pump which is generated as a result of the sudden application of acceleration to the liquid in the discharge piping.

The condition " $P_{id} < 0.1 \text{ MPa}$ " is given above as an approximate standard. If P_{id} becomes 0.1MPa or higher, vibration on the pipe is generated. So measures should be taken to cope with the influence of vibration on the pump, too.

Measures

1. Install pulsation prevention device (air chamber).
2. Enlarge the diameter and shorten the length of the discharge piping.

• Prevention of overfeeding

Pump differential pressure $>$ Inertial resistance P_i
 • The larger one of the suction side or the discharge side

Overfeeding means excessive flow of the liquid due to abnormal functioning of the check valve caused by pulsation of the liquid in the piping. Check carefully in case the differential pressure is low and in case the piping is too long even with the differential pressure value at 0.03MPa.

Measures

1. Install air chamber.
2. Install back pressure valve

• Prevention of suction failure

$NPSH_a > NPSH_r$
 $NPSH_a = P_a - P_v \pm P_{hs} - P_{is} * \text{MPa}$
 *Or P_{fs} : whichever is the larger.
 (NPSH : Net positive suction head)

If NPSH is insufficient, caution should be exercised because draining or cavitation occurs, which may result in poor performance or pump damage.

- NPSH_a : Absolute NPSH (MPa)
- NPSH_r : Required NPSH (value particular to the pump) (MPa)
- P_a : Absolute pressure onto the tank liquid surface (MPa)
- P_v : Liquid vapour pressure (MPa)
- P_{hs} : Pressure caused by the height of the suction side (MPa)
 (Flooded suction : +, Negative suction : -)
- P_{is} : Inertial resistance on the suction side (MPa)
- P_{fs} : Piping resistance on the suction side (MPa)

LK series performance

Model	Viscosity mPa·s		Slurry(Calcium hydroxide) wt%		NPSHr MPaA	Inertial resistance MPa/1m Note 1		Applicable chambers (0.3MPa) Note 2		
	PVC	SUS	PVC	SUS		50Hz	60Hz	PVC	SUS	
	LK-11 21 22 31 32 45 47 55 57	VC: 300 VH: 500	500	—		5	15	0.07	0.001	0.001
LK-A 55 57 65	1000		15	0.08	0.003			0.004	2L	1.5L
LK-B 65 75	500	1000	15	0.08	0.08	0.004	0.005	5L	5L	
LK-C 76 86 87	500	1000	15	0.08	0.08	0.004	0.005	10L	10L	
						0.003	0.003	20L	20L	
						0.007	0.009	20L	20L	
						0.013	0.020	20L	36L	

- Discharge capacity may reduce when sending viscous/slurry liquid. • Dosing flow fluctuation: $\pm 2\% \text{FS}$ • Linearity deviation: $\pm 3\% \text{FS}$
- Permissible liquid temperature PVC: 0 - 50°C, SUS: 0 - 80°C Maximum suction lift: 1m at full stroke length • Permissible ambient temperature: 0 - 40°C • Paint color: C37-60D(JPMA)

Note 1: Inertial resistance P_i is calculated per 1m on condition that the pipeline has the same bore as the pump (by pumping clean water at full stroke length).

Determine the actual P_i by the following formula.

Inertial resistance $P_{id}(P_{is}) = \text{Applicable } P_i \text{ on the table} \times \text{specific gravity} \times \text{actual pipe length (m)} \dots \dots \dots \text{ (MPa)}$ (P_{id} : Discharge side P_i , P_{is} : Suction side P_i)

If pipe bore is different from the pump bore: Inertial resistance $P_{id}(P_{is}) = \text{Applicable } P_i \text{ on the table} \times \text{specific gravity} \times \text{actual pipe length} \times (\text{Pump bore} - \text{pipe bore})^2 \dots \dots \dots \text{ (MPa)}$

Note 2: Applicable chamber: Chamber volume is based on IWAKI's standard chambers.

LK-VS type (Viscosity/slurry)

Model	Connection		Viscosity mPa·s	Slurry wt%	Materials	
	flange	hose			valve seat	valve guide
LK-11VS 2 VS 3 VS 45VS 47VS 5 VS	15A	* $\phi 12 \times \phi 18$	1000	5	*SUS304	*PVC (For VS)
		Normal		15		PVC (Normal)
	*25A	*Hose cannot be used				
	25A (Normal)	—				

Model	Connection	Viscosity mPa·s	Slurry wt%	Materials	
				valve seat	valve guide
LK-A VS B VS C VS	See the standard flange connection	1000	15	*SUS304	PVC (Normal)

- The information marked with * are for the VS type only.
- Suction-side piping should be flooded suction system.

Inverter control of LK series

In case of inverter-applied control of the discharge, the control range may be different according to the types or the pressure employed.

List of the specifications for the selection of LK series inverter control system

Model	Capacity Full stroke length L/min Note 1	Max. Pressure MPa		Control range Note 2	Stroke speed rpm	Inverter frequency Hz	Motor Note 3	Description
		PVC, PVDF	SUS					
LK-	11	0.008 - 0.032	1.0	1.5	1 : 4	19 - 78	0.2kW Standard motor (IWAKI original flange motor)	1. The frequency less than the lowest in the table cannot be used as unstable rotation of motor is expected. 2. Drive over the max. frequency cannot be made. 3. Inverter motor cannot be installed.
	21	0.02 - 0.08	1.0	1.5	1 : 4	19 - 78		
	22	0.04 - 0.12	1.0	1.5	1 : 3	38 - 116		
	31	0.10 - 0.40	1.0	1.5	1 : 4	19 - 78		
	32	0.20 - 0.60	1.0	1.5	1 : 3	38 - 116		
	45	0.33 - 1.3	0.8	0.8	1 : 4	19 - 78		
	47	0.66 - 2.0	0.8	0.8	1 : 3	38 - 116		
	55	1.37 - 4.4	0.3	0.3	1 : 3.2	24 - 78		
	57	3.6 - 7.2	0.3	0.3	1 : 2	58 - 116		
	55	0.002 - 0.024	1.0	1.5	1 : 10	5 - 58		
21	0.006 - 0.06	1.0	1.5	1 : 10	5 - 58			
22	0.012 - 0.12	1.0	1.5	1 : 10	11 - 116			
31	0.03 - 0.30	1.0	1.5	1 : 10	5 - 58			
32	0.06 - 0.60	1.0	1.5	1 : 10	11 - 116			
45	0.1 - 1.0	1.0	1.0	1 : 10	5 - 58			
47	0.2 - 1.0	—	1.5	1 : 5	11 - 58			
47	0.2 - 2.0	0.8	0.8	1 : 10	11 - 116			
55	0.33 - 3.3	0.3	0.3	1 : 10	5 - 58			
57	0.66 - 3.3	0.5	0.5	1 : 5	11 - 58			
LK-A	55	1.1 - 4.4	0.3	0.3	1 : 4	20 - 78	0.4kW Inverter motor (VF motor)	1. The frequency less than the lowest cannot be used as unstable motor rotation of motor is expected.
	57	1.8 - 7.2	0.3	0.3	1 : 4	29 - 116		
	65	3.6 - 7.2	0.5	0.5	1 : 2	58 - 116		
LK-B	65	4.5 - 14.4	0.2	0.2	1 : 3.2	25 - 78	0.75kW Inverter motor (VF motor)	2. Drive over the max. frequency cannot be used.
	75	6.7 - 21.5	0.3	0.3	1 : 3.2	24 - 78		
LK-C	76	8 - 24	0.5	0.5	1 : 3	28 - 86	1.5kW Inverter motor (VF motor)	
	86	13 - 40	0.3	0.3	1 : 3	28 - 86		
	87	18 - 54	0.3	0.3	1 : 3	38 - 116		

Note 1: The capacity is the value when the maximum discharge pressure is applied in each type (with pure water at room temperature)

Note 2: With the LK-F type, a larger control range than 1 : 10 is available. In this case, however, the discharge accuracy and the linearity may be affected due to a stroke speed as low as 15 rpm.

Note 3: The standard inverter is the Toshiba VF motor. In case of another motor used, most of the date in this list can still be used. To be sure, please contact your distributor in advance.

An inverter control with an ordinary general-purpose motor should not be employed, because it may result in trouble in the low speed range.

Note 4: When combining the following materials, the inverter frequency is "10 to 60 Hz". LK-F11VS, LK-F21VS, LK-F31VS

- This table is applied to 200V range inverter. Ask us for the inverter of other voltage.
- Two-value control by inverter and electric servo can not be done.
- It may be necessary to adjust the output torque of the motor with the inverter.

Optional accessories

Siphon preventing valve

Model	BVC-1P□L-□H	BVC-1P□-□H
Applicable capacity	Up to 1L/min	
Setting pressure	0.05 - 0.2MPa	0.2 - 0.8MPa
Material	PVC, FKM (EPDM)	
Connection mm (Applicable tube diameter)	Inlet 4 x 9, 12 x 18	Outlet PT3/8 and PT1/2

□ : Symbol for material of O-ring ("V" for FKM, "E" for EPDM)



Air chamber

Body	Model	Applicable capacity L	Setting pressure MPa	Connection Nominal size JIS10K flange	Weight kg
PVC	A-1V□	1.0	0.5	Common for 15A - 25A	2
	A-2V□	2.0			2.5
	A-5V□	5.0			4.5
	N40A-10V(2)-F *	10			16
	N50A-20V(2)-F *	20			26
SUS316	N65A-30V(2)-F *	30	0.9	10, 15, 20A	49
	A-0556-()	0.5			3
	A-156-()	1.5			5
	A-556-()	5.0			12
	A-1056-()	10			15
	A-2056-()	20			29
	A-3656-()	36			55

*: Material for O-ring 10V / 20V / 30V for CR, 10V2 / 20V2 / 30V2 for FKM

□ : Symbol for material of O-ring ("V" for FKM, "E" for EPDM)

() : Symbol for connection (10, 15, 20, 25, 40, 50 or 65)

• The weight is the value of the product only. (The weight of liquid applied is not included.)

• Rigid PVC chamber may deteriorate with ultraviolet ray or the applied chemical liquid over a long period of time. The chamber should be replaced every three years to guarantee safety.



PVC, A type

PVC, N type

SUS, A type

SUS, A type

Relief valve and back pressure valve

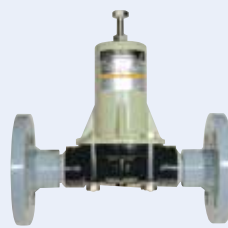

PVC type

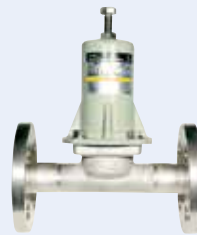

SUS type

List of relief valve

Body	Model	Max. capacity L/min	Setting pressure MPa	Connection Nominal size JIS10K flange	Weight kg
PVC	RV-1P□-4H	1.0	0.3 - 0.8	ø4 x ø9 PVC Hose	0.2
	RV-1P□-12H	1.0	0.3 - 0.8	ø12 x ø18 PVC Hose	0.2
	RV-1P□-15	1.0	0.3 - 0.8	15A	0.5
	RV-1P□-20	1.0	0.3 - 0.8	20A	0.5
	RV-1P□B-15	1.0	0.8 - 1.0	15A	0.5
	RV-3P-15	3.0	0.3 - 1.0	15A	0.6
	RV-3P-20	3.0	0.3 - 1.0	20A	0.6
	RV-3P-25	3.0	0.3 - 1.0	25A	0.9
	RV-3P□-12H	3.0	0.3 - 1.0	ø12 x ø18 PVC Hose	0.4
	RV-7V-20	7.5	0.3 - 0.8	20A	3.5
	RV-7V-25	7.5	0.3 - 0.8	25A	3.5
	RV-7VB-20	7.5	0.8 - 1.0	20A	3.5
	RV-7VB-25	7.5	0.8 - 1.0	25A	3.5
	RV-25V-25	25	0.3 - 0.8	25A	4
	RV-25V-40	25	0.3 - 0.8	40A	4
	RV-25V-50	25	0.3 - 0.8	50A	4.5
	N50RV-5V-F	50	0.15 - 0.5	50A	20
	N50RV-5V2-F	50	0.15 - 0.5	50A	20
	N65-50RV-5V-F	70	0.15 - 0.5	65A	20
N65-50RV-5V2-F	70	0.15 - 0.5	65A	20	
SUS	RV-256-15	2.0	0.3 - 0.8	JIS10 - 16K 15A	3.5
	RV-256B-15	2.0	0.8 - 1.5	JIS10 - 16K 15A	3.5
	RV-756-25	7.5	0.3 - 0.8	JIS10 - 16K 25A	6
	RV-756B-25	7.5	0.8 - 1.5	JIS10 - 16K 25A	6
	RV-2556-25	25	0.3 - 0.8	25A	7.0
	RV-2556B-25	25	0.8 - 1.0	25A	7.0
	RV-2556-40	25	0.3 - 0.8	40A	7.5
	RV-2556-50	25	0.3 - 0.8	50A	8.7
	RV-2556B-40	25	0.8 - 1.0	40A	7.5
	N50RV-556-F	80	0.15 - 0.5	50A	29
	N65RV-556-F	120	0.15 - 0.5	65A	42

□ : Symbol for material of O-ring ("V" for FKM, "E" for EPDM)

O-ring material of N type is "SV2" for FKM.

• Material for diaphragm is PTFE except RV-1P and N type.

Material of diaphragm is same as O-ring material at RV-1P and N type.

List of back pressure valve

Body	Model	Max. capacity L/min	Setting pressure MPa	Connection Noeminal size JIS10K flange	Weight kg
PVC	BV-1P□-4H	0.005 - 1.0	0.2 - 0.8	ø4 x ø9 PVC Hose	0.2
	BV-1P□-12H	0.005 - 1.0	0.2 - 0.8	ø12 x ø18 PVC Hose	0.2
	BV-1P□-15	0.005 - 1.0	0.2 - 0.8	15A	0.5
	BV-1P□-20	0.005 - 1.0	0.2 - 0.8	20A	0.5
	BV-1P□L-4H	0.005 - 1.0	0.05 - 0.2	ø4 x ø9 PVC Hose	0.2
	BV-1P□L-12H	0.005 - 1.0	0.05 - 0.2	ø12 x ø18 PVC Hose	0.2
	BV-1P□L-15	0.005 - 1.0	0.05 - 0.2	15A	0.5
	BV-1P□L-20	0.005 - 1.0	0.05 - 0.2	20A	0.5
	BV-3P□-12H	0.03 - 3.0	0.1 - 0.8	ø12 x ø18 PVC Hose	0.4
	BV-3N□-12H	0.005 - 3.0	0.1 - 0.3	ø12 x ø18 PVC Hose	0.4
	BV-3N□-15	0.005 - 3.0	0.1 - 0.3	15A	0.6
	BV-3N□-20	0.005 - 3.0	0.1 - 0.3	20A	0.6
	BV-3N□-25	0.005 - 3.0	0.1 - 0.3	25A	0.9
	BV-7V-20	0.2 - 7.5	0.05 - 0.8	20A	3.5
	BV-7V-25	0.2 - 7.5	0.05 - 0.8	25A	3.5
	BV-25V-25	2 - 25	0.1 - 0.8	25A	4
	BV-25V-40	2 - 25	0.1 - 0.8	40A	4
	BV-25V-50	2 - 25	0.1 - 0.8	50A	4.5
	N50BV-5V-F	2.5 - 50	0.15 - 0.5	50A	18
N50BV-5V2-F	2.5 - 50	0.15 - 0.5	50A	18	
SUS	N65-50BV-5V-F	5 - 70	0.15 - 0.5	65A	20
	N65-50BV-5V2-F	5 - 70	0.15 - 0.5	65A	20
	BV-256-15	0.02 - 2.0	0.05 - 0.8	JIS10 - 16K 15A	3.5
	BV-756-25	0.2 - 7.5	0.05 - 0.8	JIS10 - 16K 25A	6.0
	BV-2556-25	2 - 25	0.1 - 0.8	25A	7.0
	BV-2556-40	2 - 25	0.1 - 0.8	40A	7.5
	BV-2556-50	2 - 25	0.1 - 0.8	50A	8.5
N50BV-556-F	2.5 - 80	0.15 - 0.5	50A	29	
N65BV-556-F	5 - 120	0.15 - 0.5	65A	42	

□ : Symbol for material of O-ring ("V" for FKM, "E" for EPDM)

O-ring material or N type is "SV" for CR, or "SV2" for FKM.

• Material for diaphragm is PTFE except BV-1P and N type.

Material of diaphragm is same as O-ring material at BV-1P and N type.

• The back pressure valve can not curb the residual flow completely when the pump stops. Use the solenoid valve in order to shut out the residual flow.

Dimensions (in mm)

Dimensions may be changed without prior notice for the purpose of product improvement. Be sure to carry out installation work with the most recent and detailed drawings, which are available upon request

LK-11 to LK-57 (Original motor type)

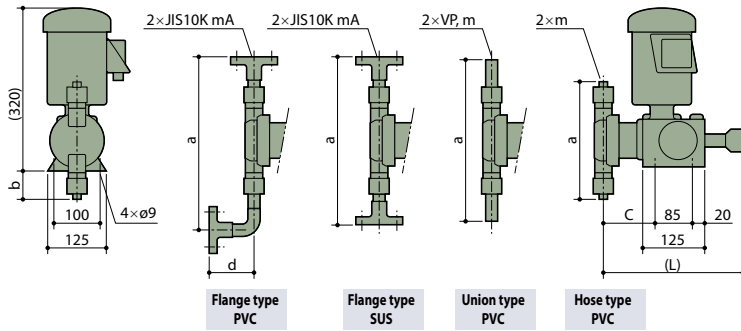

Model	Hose type PVC					Union type PVC					Flange type PVC					Flange type SUS					
	L	a	b	c	m	L	a	b	c	m	L	a	b	c	d	m	L	a	b	c	m
LK-1	274	146	23	95		274	244	72	95	16	275	264	86	95	89	15	272	141	20	92	15
2	274	164	32	95		274	262	81	95	16	275	282	95	95	89	15	272	151	25	92	15
3	277	224	62	97	Note 1	277	318	109	97	16	277	342	125	97	89	15	277	184	42	97	15
4	281	249	75	99		281	342	120	99	16	281	361	135	99	89	15	283	261	80	101	15
5	-	-	-	-	298	314	107	114	25	298	338	125	114	97	25	295	320	111	111	25	
47VS	-	-	-	-	281	272	86	99	25	281	313	106	99	97	25	-	-	-	-	-	

Note 1: Connection size LK-1 and LK-2 ø4mm x ø9mm, LK-3, LK-4 and LK-1 to LK-45 VS type ø12mm x ø18mm. For information of TC type, please contact IWAKI or nearest distributor.

LK-A55 to LK-C87 (General purpose motor type)

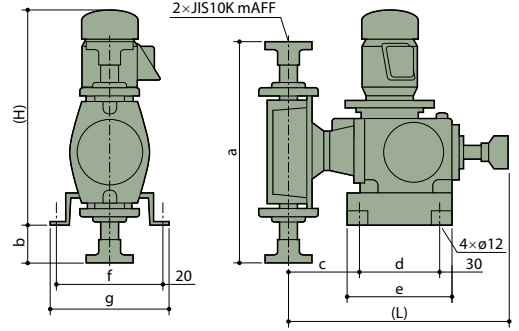

Model	PVC					SUS					Note 2							
	L	a	b	c	m	L	a	b	c	m	L	a	b	c	d	e	f	g
LK-A5	476	325	-29	119		473	320	-32	108		547	180	240	260	300	300	25	
A6	532	599	108	154		533	431	24	164		547	180	240	260	300	40		
B6	595	599	90	164		605	431	6	174		594	240	300	310	350	40		
B7	599	600	90	167		610	465	23	178		594	240	300	310	350	50		
C7	599	600	90	167		610	465	23	178		601	240	300	310	350	50		
C8	605	647	114	173		609	633	107	177		601	240	300	310	350	65		

Note 2: These dimensions are common between PVC pump head and SUS pump head.

LK-F1 to F5 (General purpose motor type)

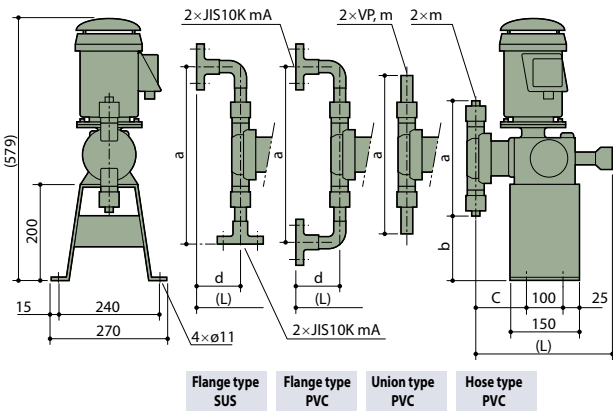

Model	Hose type PVC					Union type PVC					Flange type PVC					Flange type SUS						
	L	a	b	c	m	L	a	b	c	m	L	a	b	c	d	m	L	a	b	c	d	m
LK-F1	274	146	177	87		274	244	128	87	16	363	272	114	87	89	15	332	156	180	85	60	15
2	274	164	168	87	Note 1	274	262	119	87	16	363	290	105	87	89	15	332	166	175	85	60	15
3	277	224	138	89		277	318	91	89	16	366	350	75	89	89	15	337	201	158	90	60	15
4	281	249	128	92	281	342	79	92	16	370	369	65	92	89	15	343	270	120	94	60	15	
5	-	-	-	-	298	314	93	107	25	395	350	75	107	97	25	399	368	90	104	104	25	
47VS	-	-	-	-	281	272	114	92	25	378	313	94	92	97	25	-	-	-	-	-	-	

Note 1: Connection size LK-1 and LK-2 ø4mm x ø9mm, LK-3, LK-4 and LK-1 to LK-45 VS type ø12mm x ø18mm. For information of TC type, please contact IWAKI or nearest distributor.

Pump controller MFC

Multifunction pump controller for LK-F series metering pumps

- Capable of analogue input (4~20mA) and pulse input (Dividing/Multiply) operation
- Operating functions of the pump can be monitored via external output signal.
- Easy key touch operation and a large LCD display give good control legibility.
- Display preference of flow rate (L/min) or stroke rate (SPM) is user-selectable.
- Combination of stroke length adjustment with stroke rate enables flow volume control over a wide range of 1:480.

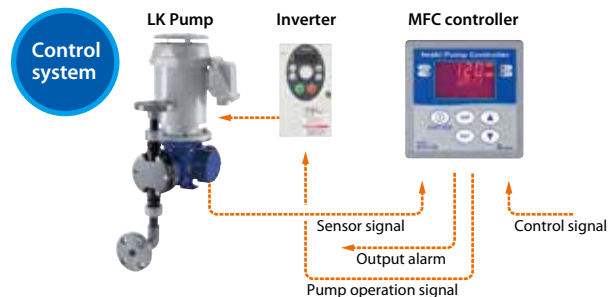

IWAKI CO., LTD. 6-6 Kanda-Sudacho 2-chome Chiyoda-ku Tokyo 101-8558 Japan TEL : (81)3 3254 2935 FAX : 3 3252 8892 IWAKI has global net work. Please find your distributor location at www.iwakipumps.jp

<p>European office :</p> <ul style="list-style-type: none"> IWAKI Europe GmbH Germany IWAKI Europe GmbH (Netherlands Branch) Holland IWAKI Europe GmbH (Italy Branch) Italy IWAKI Europe GmbH (Spain Branch) Spain IWAKI Belgium N.V. Belgium IWAKI Nordic A/S Denmark IWAKI Suomi Oy Finland IWAKI France S.A. France IWAKI Norge AS Norway IWAKI Sverige AB Sweden IWAKI Pumps (UK) Ltd. U.K. 	<p>TEL: (49)2154 9254 0 FAX: 2154 9254 48</p> <p>TEL: (49)2154 9254 50 FAX: 2154 9254 55</p> <p>TEL: (31)74 2420011 FAX: (49)2154 925448</p> <p>TEL: (39)0444 371115 FAX: 0444 335350</p> <p>TEL: (34)93 37 70 198 FAX: 93 47 40 991</p> <p>TEL: (32)13 67 02 00 FAX: 13 67 20 30</p> <p>TEL: (45)48 24 2345 FAX: 48 24 2346</p> <p>TEL: (358)9 2745810 FAX: 9 2742715</p> <p>TEL: (33)1 69 63 33 70 FAX: 1 64 49 92 73</p> <p>TEL: (47)23 38 49 00 FAX: 23 38 49 01</p> <p>TEL: (46)8 511 72900 FAX: 8 511 72922</p> <p>TEL: (44)1743 231363 FAX: 1743 366507</p> <p>()Country codes</p>	<p>U.S.A. : IWAKI America Inc.</p> <p>Argentina : IWAKI America Inc. (Argentina Branch)</p> <p>Brazil : IWAKI Do Brasil Comercio De Bombas Hidraulicas LTDA.</p> <p>Singapore : IWAKI Singapore Pte Ltd.</p> <p>Indonesia : IWAKI Singapore (Indonesia Office)</p> <p>Malaysia : IWAKIm Sdn. Bhd.</p> <p>Australia : IWAKI Pumps Australia Pty Ltd.</p> <p>Hong Kong : IWAKI Pumps Co., Ltd.</p> <p>China : GFIZ IWAKI Engineering & Trading Co., Ltd.</p> <p>India : IWAKI Pumps (Shanghai) Co., Ltd.</p> <p>Korea : IWAKI Korea Co., Ltd.</p> <p>Taiwan : IWAKI Pumps Taiwan Co., Ltd.</p> <p>Thailand : IWAKI (Thailand) Co., Ltd.</p>	<p>TEL: (1)508 429 1440 FAX: 508 429 1386</p> <p>TEL: (54)11 4745 4116 FAX: (55)19 3244 5900</p> <p>TEL: (65)6316 2028 FAX: 6316 3221</p> <p>TEL: (62)21 6906606 FAX: 21 6906612</p> <p>TEL: (60)3 7803 8807 FAX: 3 7803 4800</p> <p>TEL: (61)2 9899 2411 FAX: 2 9899 2421</p> <p>TEL: (852)2607 1168 FAX: 2607 1000</p> <p>TEL: (86)20 84350603 FAX: 20 84359181</p> <p>TEL: (86)21 6272 7502 FAX: 21 6272 6929</p> <p>TEL: (82)2 2630 4800 FAX: 2 2630 4801</p> <p>TEL: (886)2 8227 6900 FAX: 2 8227 6818</p> <p>TEL: (66)2 322 2471 FAX: 2 322 2477</p>
--	--	---	--

Caution for safety use: Before use of pump, read instruction manual carefully to use the product correctly. Actual pumps may differ from the photos. Specifications and dimensions are subject to change without prior notice. For further details please contact us.

Legal attention related to export. Our products and/or parts of products fall in the category of goods contained in control list of international regime for export control. Please be reminded that export license could be required when products are exported due to export control regulations of countries. The posting and copying from this catalogue without permission is not accepted firmly.