



IWAKI
AIR
PUMPS

APN



Most appropriate for built-in applications

Diaphragm air pumps



The APN series, diaphragm air pumps, are compact and have motor-driven diaphragms. A highly-efficient motor and a special diaphragm, an enlarged bearing and an enhanced connecting rod have greatly improved vacuum performance, a starting characteristic and durability. The APN can fit to various applications, including gas sampling and medical equipment.

Clean air transfer

The motor-driven diaphragm pumps are oil-/carbon-free and are highly air-tight. Most suitable in medical or sampling equipment where air cleanness is required.

Highly-efficient design

A use of moulded parts enhances the pump performance and efficiency. The high-power motor also improves the starting characteristic.

Long life design

Fiber reinforced diaphragms, enlarged bearings and enhanced con rods have further improved reliability and durability in order for the pump to run over an extended time period in a continuous operation.

Easy maintenance

The pump head consists of only a few parts and can easily be dismantled and assembled.

Wide variations

Either single- or twin-head type is selectable. Also, EPDM, FKM, NBR or PTFE diaphragm and hose/thread connections are available. A number of combinations (more than 60) varies the APN according to an intended use.

NOTE: A diaphragm material and a suction bore shape differs with models.

Applications

Analysers

Deaerator, Air analyser, Flue-gas analyser, Biochemical analyser, Spectral photometer, Leak tester and Dust counter.

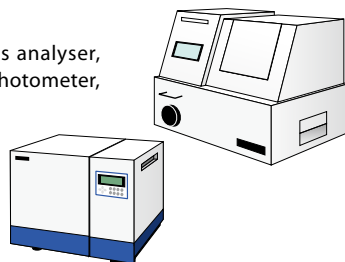

Printing and Automatic processing

Copy machine (paper transfer), Printing machine (film adsorption/ paper transfer), Automatic processor (blower), Printer, Air bearing and Automatic stamper.

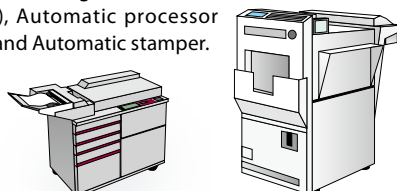

Medical equipment

Aspirator, Nebulizer, Low-frequency therapy equipment, Blood-pressure gauge, Endoscope, X-ray film adsorption/transfer, Gas sterilizer, Tapper, Artificial respirator, Bedsore preventive mat, Interferential current therapy equipment, Oxygen generator and Normal saline solution spray.

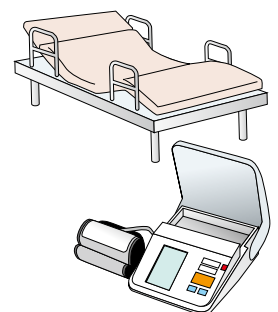

Electronics

PCB adsorption/transfer, Clean bench, Wafer adsorption/transfer, Semiconductor manufacturing equipment, Laser equipment and Micro air duster.

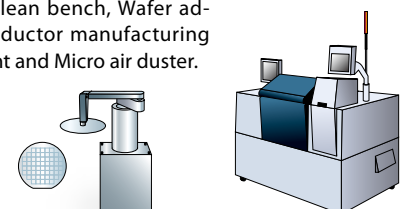

Either single or twin pump head type is selectable.
 Thread and hose connections allow the pump to fit into various applications.

Max. Vacuum kPa				Max. discharge pressure MPa				Model	Pump head	Max. capacity L/min (50Hz)				
26.66	53.32	79.98	101.31	0	0.05	0.1	0.15			0.2	0	2.5	5	7.5
[Bar chart: 79.98-101.31]				[Bar chart: 0-0.05]				APN-051L/H	Single	[Bar chart: 0-2.5]				
[Bar chart: 79.98-101.31]				[Bar chart: 0-0.05]				APN-P051L/H	Parallel	[Bar chart: 0-2.5]				
[Bar chart: 26.66-79.98]				[Bar chart: 0-0.05]				APN-S051L	Series	[Bar chart: 0-2.5]				
[Bar chart: 79.98-101.31]				[Bar chart: 0-0.05]				APN-052L/H	Single	[Bar chart: 0-2.5]				
[Bar chart: 79.98-101.31]				[Bar chart: 0-0.05]				APN-P052L/H	Parallel	[Bar chart: 0-2.5]				
[Bar chart: 26.66-79.98]				[Bar chart: 0-0.05]				APN-S052L/H	Series	[Bar chart: 0-2.5]				
[Bar chart: 79.98-101.31]				[Bar chart: 0-0.05]				APN-052L/H-D	Single	[Bar chart: 0-2.5]				
[Bar chart: 26.66-79.98]				[Bar chart: 0-0.05]				APN-085	Single	[Bar chart: 0-2.5]				
[Bar chart: 26.66-79.98]				[Bar chart: 0-0.05]				APN-085L/H	Single	[Bar chart: 0-2.5]				
[Bar chart: 26.66-79.98]				[Bar chart: 0-0.05]				APN-085L/H-D4	Single	[Bar chart: 0-2.5]				
[Bar chart: 26.66-79.98]				[Bar chart: 0-0.05]				APN-P085L/H	Parallel	[Bar chart: 0-2.5]				
[Bar chart: 26.66-79.98]				[Bar chart: 0-0.05]				APN-S085L/H	Series	[Bar chart: 0-2.5]				
[Bar chart: 26.66-79.98]				[Bar chart: 0-0.05]				APN-110K/L	Single	[Bar chart: 0-25]				
[Bar chart: 26.66-79.98]				[Bar chart: 0-0.05]				APN-110K/L-D4	Single	[Bar chart: 0-25]				
[Bar chart: 26.66-79.98]				[Bar chart: 0-0.05]				APN-P110K/L	Parallel	[Bar chart: 0-25]				
[Bar chart: 26.66-79.98]				[Bar chart: 0-0.05]				APN-S110L	Series	[Bar chart: 0-25]				
[Bar chart: 53.32-79.98]				[Bar chart: 0-0.05]				APN-215N	Single	[Bar chart: 0-25]				
[Bar chart: 53.32-79.98]				[Bar chart: 0-0.05]				APN-215C	Single	[Bar chart: 0-25]				
[Bar chart: 26.66-79.98]				[Bar chart: 0-0.05]				APN-215M	Single	[Bar chart: 0-25]				
[Bar chart: 53.32-79.98]				[Bar chart: 0-0.05]				APN-P215N	Parallel	[Bar chart: 0-25]				
[Bar chart: 53.32-79.98]				[Bar chart: 0-0.05]				APN-P215C	Parallel	[Bar chart: 0-25]				
[Bar chart: 26.66-79.98]				[Bar chart: 0-0.05]				APN-P215M	Parallel	[Bar chart: 0-25]				
[Bar chart: 26.66-79.98]				[Bar chart: 0-0.05]				APN-S215M	Series	[Bar chart: 0-25]				
[Bar chart: 53.32-79.98]				[Bar chart: 0-0.05]				APN-240N	Single	[Bar chart: 0-25]				
[Bar chart: 26.66-79.98]				[Bar chart: 0-0.05]				APN-240M	Single	[Bar chart: 0-25]				
[Bar chart: 53.32-79.98]				[Bar chart: 0-0.05]				APN-P240N	Parallel	[Bar chart: 0-25]				
[Bar chart: 26.66-79.98]				[Bar chart: 0-0.05]				APN-P240M	Parallel	[Bar chart: 0-25]				
[Bar chart: 26.66-79.98]				[Bar chart: 0-0.05]				APN-S240M	Series	[Bar chart: 0-25]				
[Bar chart: 26.66-79.98]				[Bar chart: 0-0.05]				APN-450N	Single	[Bar chart: 0-25]				
[Bar chart: 26.66-79.98]				[Bar chart: 0-0.05]				APN-P450N	Parallel	[Bar chart: 0-25]				
[Bar chart: 26.66-79.98]				[Bar chart: 0-0.05]				APN-S450N	Series	[Bar chart: 0-25]				

Physics and chemistry

Vacuum furnace, Aspirator, Vacuum filtration, Liquid chromatography, Particle counter, Leak tester, Spray, Turbidimeter, Culture apparatus, Aseptic bath, Micro air duster and Agitator

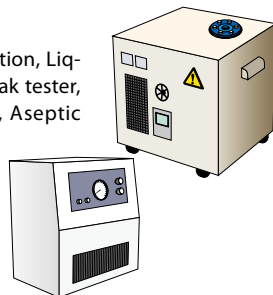

Industrial machine

Forming machine (vacuum defoaming), Solder adsorption, Washer, Vacuum tweezer, Automatic packaging, Automobile oil charger, Ozonizer, Vacuum chuck, Glass engraver, Solvent recovery, Lifter, Air tool, Air brush and air duster.

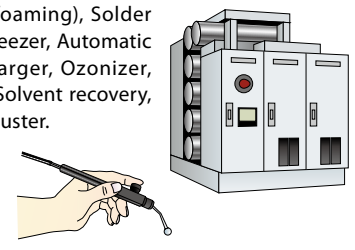

Food industry and Automatic dispenser

Food pack (vacuum packaging), Automatic dispenser, Thawing machine, Labelling machine, Bubbling machine and Deaerator

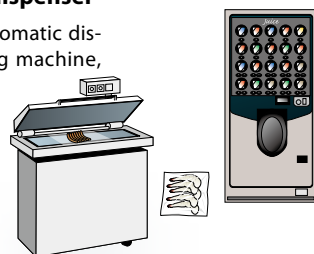

Aquarium fish and Live fish

Blower, Ozonizer, Air lift and Underwater camera

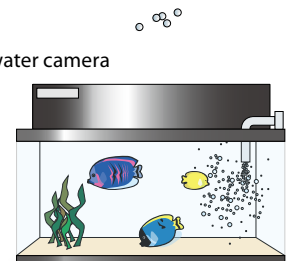

Pump variations

Single head type



Twin parallel heads type



Twin series heads type



Pump identification

APN - S 110 K N X - 1 - 02

Pump head
 No code : Single head
S : Dual-head with series tubing
P : Dual-head with parallel tubing

Model
110

Inlet/outlet
K : Parallel type
L : In-line type

Diaphragm/Valve materials
E : EPDM
V : FKM

Pump connection
 No code : Ø8 tube connection
X : Rc1/4 female thread connection
X1 : G1/4 female thread connection

Special specification

Power voltage
1 : 100VAC
2 : 200VAC
3 : 115VAC
4 : 220/240VAC
D1 : 12VDC
D2 : 24VDC
D3 : Brushless 24VDC
 (Uncontrollable)
D4 : Brushless 24VDC
 (Controllable)

This identification is APN-110 type.
 Please inform us of other types.

Pump application guide

Available Available Not Available

Model	Compressor	Vacuum	Pumphead			Connection					
			Single	Parallel	Series	Hose Parallel	Hose Straight	Hose Vertical	Thread Parallel	Thread Straight	Thread Vertical
APN-051L	Available	Available	Available	Available	Available	Not Available	Available	Not Available	Not Available	Not Available	Not Available
APN-051H	Available	Available	Available	Available	Not Available	Not Available	Not Available	Available	Not Available	Not Available	Not Available
APN-051H5	Available	Available	Available	Available	Not Available	Not Available	Not Available	Available	Not Available	Not Available	Not Available
APN-052L	Available	Available	Available	Available	Available	Not Available	Available	Not Available	Not Available	Not Available	Not Available
APN-052H	Available	Available	Available	Available	Not Available	Not Available	Not Available	Available	Not Available	Not Available	Not Available
APN-052H5	Available	Available	Available	Available	Not Available	Not Available	Not Available	Available	Not Available	Not Available	Not Available
APN-085	Available	Available	Available	Available	Available	Not Available	Not Available	Available	Not Available	Not Available	Available
APN-085L	Available	Available	Available	Available	Available	Not Available	Not Available	Available	Not Available	Available	Not Available
APN-085H	Available	Available	Available	Available	Not Available	Not Available	Not Available	Available	Not Available	Not Available	Available
APN-085 (Brushless type)	Available	Available	Available	Available	Not Available	Not Available	Not Available	Available	Not Available	Not Available	Available
APN-085L (Brushless type)	Available	Available	Available	Available	Not Available	Not Available	Available	Not Available	Not Available	Available	Not Available
APN-085H (Brushless type)	Available	Available	Available	Available	Not Available	Not Available	Not Available	Available	Not Available	Not Available	Available
APN-110K	Available	Available	Available	Available	Available	Available	Not Available	Not Available	Available	Not Available	Not Available
APN-110L	Available	Available	Available	Available	Available	Not Available	Available	Not Available	Not Available	Available	Not Available
APN-110K (Brushless type)	Available	Available	Available	Available	Not Available	Not Available	Not Available	Available	Not Available	Not Available	Not Available
APN-110L (Brushless type)	Available	Available	Available	Available	Not Available	Not Available	Available	Not Available	Not Available	Available	Not Available
APN-215N	Available	Available	Available	Available	Not Available	Available	Not Available	Not Available	Available	Not Available	Not Available
APN-215C	Available	Not Available	Available	Available	Not Available	Available	Not Available	Not Available	Available	Not Available	Not Available
APN-215M	Not Available	Available	Available	Available	Available	Available	Not Available	Not Available	Available	Not Available	Not Available
APN-240NA	Available	Available	Available	Available	Not Available	Available	Not Available	Not Available	Available	Not Available	Not Available
APN-240MA	Available	Available	Available	Available	Not Available	Available	Not Available	Not Available	Available	Not Available	Not Available
APN-450NA	Available	Available	Available	Available	Available	Available	Not Available	Not Available	Available	Not Available	Not Available
APN-450NS	Available	Available	Available	Available	Available	Available	Not Available	Available	Not Available	Not Available	Available

Specifications AC115V(60Hz)/AC220-240V(50Hz)

Model	Max.capacity L/min			Max.discharge pressure MPa	Max.vacuum kPa	Connection size		Motor						Mass kg									
	AC 115V	AC 220-240V	DC			Hose	Screw	Input W			Current A												
								AC 115V	AC 220-240V	DC	AC 115V	AC 220-240V	DC										
APN-051L/H/H5	0.7	0.6	—	0.05	61.32	ø8	Rc1/8	15	14	—	0.15	0.14	—	0.5									
APN-P051L/H/H5	1.4	1.2						20	18	—	0.2	0.18	—	0.85									
APN-S051L	1.8	1.5						—	13.33	ø8	—	—	—	—	—	—	—						
APN-052L/H/H5	2.1	1.8	—	0.05	61.32	ø8	Rc1/8	15	15	—	0.15	0.15	—	0.5									
APN-P052L/H/H5	4.2	3.6						36	30	—	0.36	0.3	—	0.85									
APN-S052L	3.6	3.0						—	13.33	ø8	—	—	—	—	—	—	—						
APN-051L-D3	—	—	1.0	0.05	61.32	ø8	—	—	—	0.8(DC24V)	—	—	0.25(DC24V)	0.5									
APN-052L/H-D1	—	—	1.8	0.05	61.32	ø8	ø5	—	—	4.8(DC12V)	—	—	1.25(DC12V)	0.5									
APN-052L/H-D2	—	—						—	—	4.9(DC24V)	—	—	0.63(DC24V)										
APN-085	6.0	5.0						—	0.08	34.66	ø8	Rc1/4 G1/4	25		29	—	0.15	0.11	—	1.9			
APN-085L/H			—	—	15	—	—						1.2	1.3									
APN-085L/H-D4			—	—	—	—	—						—	—	—	—	—	—	—				
APN-P085L/H			12	10	—	—	7.99						38	38	—	0.3	0.15	—	2.6				
APN-S085L	6.0	5.0	—	—	7.99	—	—	—	—	—	0.23	—	2.5										
APN-110K	14	12	—	0.1	23.99	ø8	Rc1/4 G1/4	—	48	—	—	0.23	—	2.5									
APN-110L								—	—	15	—	—	1.4	1.5									
APN-110K/L-D4								—	—	14	0.05	—	—	—	—	—	—	—	—				
APN-P110L								28	24	—	0.1	—	68	—	—	0.33	—	—	3.8				
APN-S110L	14	12	—	—	7.99	—	—	—	—	—	—	—	—										
APN-215N	18	15	—	0.1	39.99	ø9	G1/8	64	64	—	0.56	0.3	—	3.5									
APN-215C				0.2	—																		
APN-215M				—	26.66																		
APN-P215N				32	28										0.1	39.99							
APN-P215C				36	30										0.2	—							
APN-P215M															—	26.66							
APN-S215M	18	15	—	7.99	—	—	—	—	—	—	—	—											
APN-240NAN	34	30	—	0.2	41.32	ø14	G1/4	60	60	—	2.1	1.2	—	7.0									
APN-240MAN	36	32		—	21.33																		
APN-P240NAN	68	60		0.2	41.32																		
APN-P240MAN	72	64		—	21.33																		
APN-S240MANX	36	32		—	6.67										—	Rc1/4	90	90	—	3.2	1.9	—	10.0
APN-450NA/S	60	50		—	0.1										13.33	ø12	Rc1/4	345	312(220V) 308(240V)	—	3.1	1.5 • 1.4	—
APN-P450NA/S	110	100	—	—	3.33	—	—	—	—	—	—	—	—	A12.8 S17.1									
APN-S450NA/S	60	50	—	—	3.33	—	—	—	—	—	—	—	—	A13.0 S17.4									

•Air flow temperature : 0-40°C •Ambient temperature : 5-40°C

Construction

051L/052L

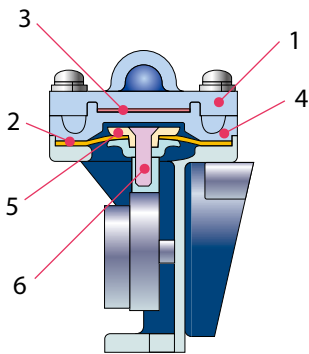

110K

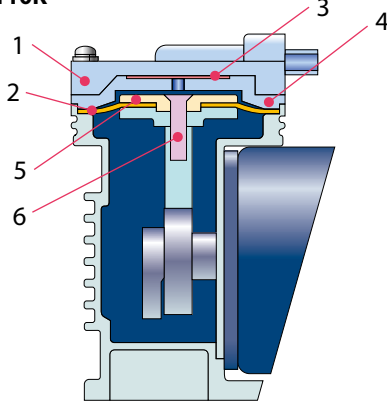

240NA

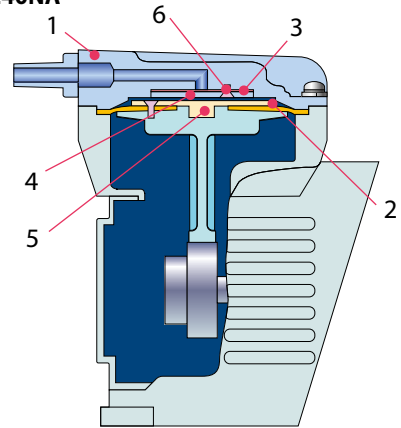

085,085L

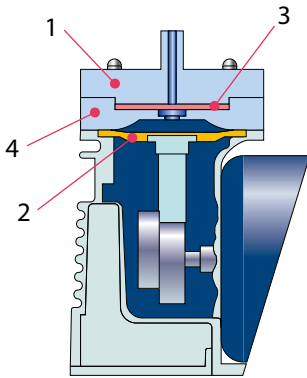

APN-085

215N/215M,215C

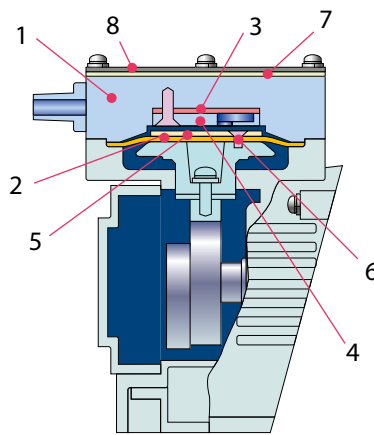

APN-215N / 215M

450NA

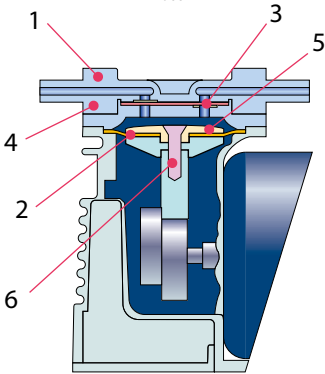
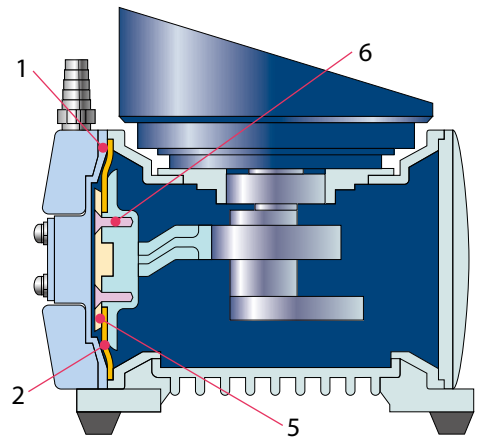

APN-085L

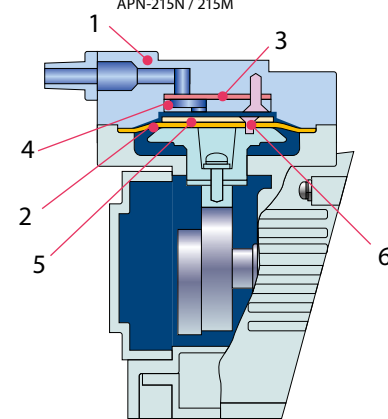

APN-215C

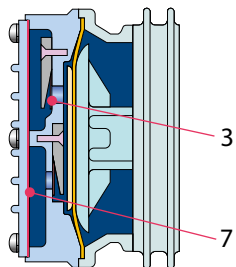

List of Available Materials

Symbol of Material	Name		
GFRPP	Glass-fiber-reinforced polypropylene	EPDM	Ethylene propylene rubber
GFRPPS	Glass-fiber-reinforced polyphenylene sulfide resin	NBR	Nitrile butadiene rubber
GFRPA	Glass-fiber-reinforced polyamide resin	ADC12	Aluminum diecast
PTFE	Tetra-fluoroethylene resin	SUS304	Stainless steel 304
FKM	Fluorocarbon rubber	SUS631-CSP	Stainless steel (strip steel for spring)

Materials

Model	051L,052L		085,085L			110K		215N		215C		215M		240	450		
	V	E	V	E	N	V	E	V	E	V	E	V	E		AT	ST	
1 Pump head	GFRPP		GFRPP			GFRPP		GFRPA		ADC12		GFRPP		ADC12	ADC12	SUS304	
2 Diaphragm	PTFE+EPDM	EPDM	FKM	EPDM	NBR	FKM	EPDM	FKM	EPDM	FKM	EPDM	FKM	EPDM	NBR	PTFE+EPDM		
3 Valve	FKM	EPDM	FKM	EPDM	NBR	FKM	EPDM	FKM	EPDM	FKM	EPDM	FKM	EPDM	FKM	SUS631-CSP		
4 Valve seat	GFRPP		GFRPP			GFRPP				GFRPPS				ADC12			
5 Retainer plate	GFRPPS		GFRPPS			GFRPPS				GFRPPS				ADC12	ADC12	SUS304	
6 Screw	SUS304		SUS304			SUS304		SUS304		SUS304	SUS304	SUS304		SUS304	SUS304		
7 Seal gasket	—		—			—		FKM	EPDM	—		FKM	EPDM	—		EPDM	FKM
8 Pump head cover	—		—			—		SUS304		—		GFRPP		—		—	

Performance curves

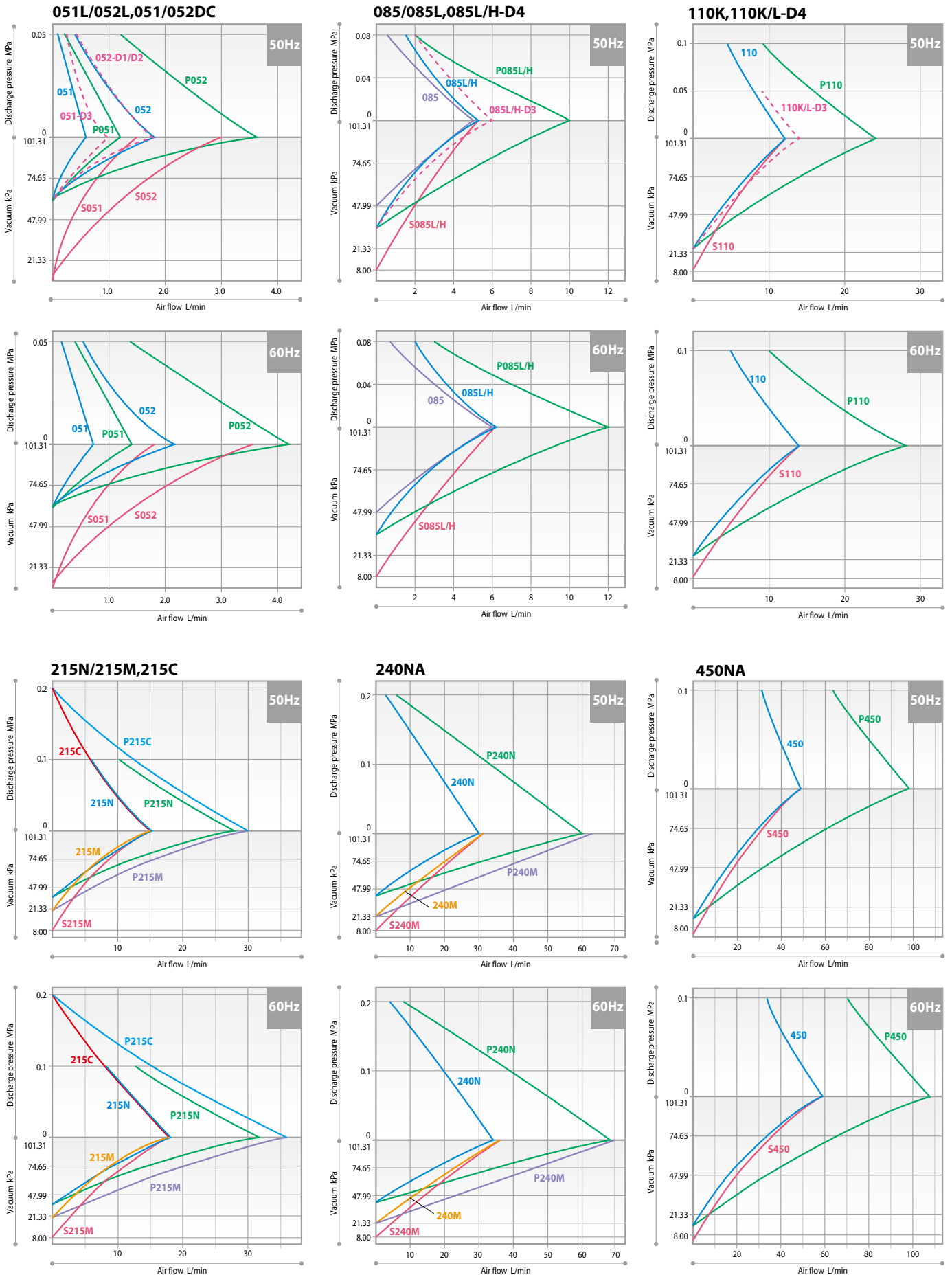

Dimensions in mm

APN-052

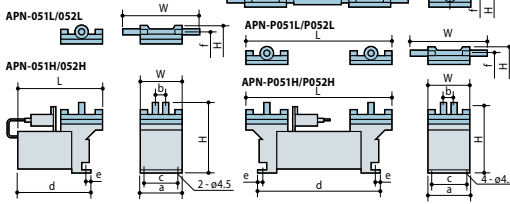

Model	W	H	L	a	b	c	d	e	f
APN-051L/052L	86 (75)	(94)	46	—	32	(80)*	6.5	67	—
APN-051H/052H	46 (78)	—	—	—	—	—	—	—	—

* Motor D1/D2: (77mm), Motor D3: (76mm)

APN-085

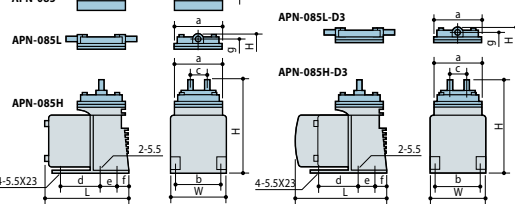

Model	W	H	L	a	b	c	d	e	f	g
APN-085	(136)	—	—	—	24	—	—	—	—	—
APN-085L	82.4 (121)	(124)	—	—	—	—	21.5	—	111	—
APN-085H	(140)	—	—	72	66	24	57	18.5	—	—
APN-085L-D4	(80)	(121)	(130)	—	—	—	—	23	—	—
APN-085H-D4	(140)	—	—	—	—	—	—	—	—	—

APN-P085L

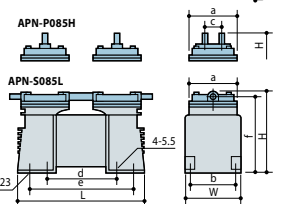

Model	W	H	L	a	b	c	d	e	f
APN-P085L	(121)	—	—	106	—	—	—	—	111
APN-P085H	82.4 (140)	(188)	—	—	72	66	24	108	151
APN-S085L	(121)	—	—	—	—	—	—	—	111

APN-110

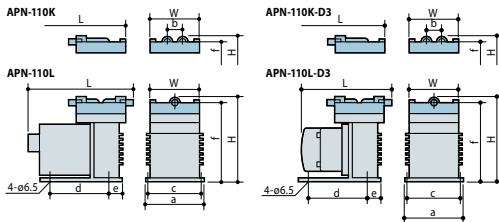

Model	W	H	L	a	b	c	d	e	f
APN-110K	(152)	—	—	24	—	—	—	—	—
APN-110L	78 (134)	(164)	86	74	91	24	124	—	—
APN-110K-D4	(129)	—	—	—	—	—	—	—	—
APN-110L-D4	(141)	—	—	—	—	—	—	—	—

Model	W	H	L	a	b	c	d	e	f
APN-S110L	78 (134)	(236)	86 (104)	74 (154)	24 (124)	—	—	—	—
APN-P110L	102 (134)	(212)	86 (104)	74 (154)	24 (124)	—	—	—	—

APN-215

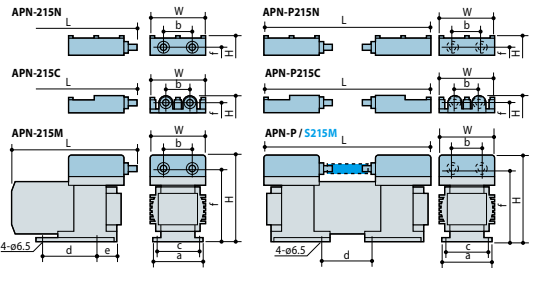

Model	W	H	L	a	b	c	d	e	f
APN-215N	(147)	—	—	50	—	—	—	(125)	—
APN-215C	Ø96 (140)	(195)	90	39	74	91	36	(130)	—
APN-215M	(151)	—	—	50	—	—	—	(125)	—

Model	W	H	L	a	b	c	d	e	f
APN-P215N	(147)	—	—	50	—	—	—	(125)	—
APN-P215C	Ø96 (140)	(282)	110	39	78	(90)	—	(130)	—
APN-P/S215M	(151)	—	—	50	—	—	—	(125)	—

APN-240

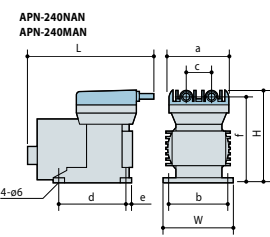

Model	W	H	L	a	b	c	d	e	f
APN-240NAN	140 (186)	(219)	122	125	48	135	(26)	(173)	—
APN-240MAN	—	—	—	—	—	—	—	—	—

Model	W	H	L	a	b	c	d	e	f
APN-P240NAN	140 (186)	(297)	122	125	48	(245)	(173)	—	—
APN-S240MANX	—	—	—	—	—	—	—	—	(30)

APN-450

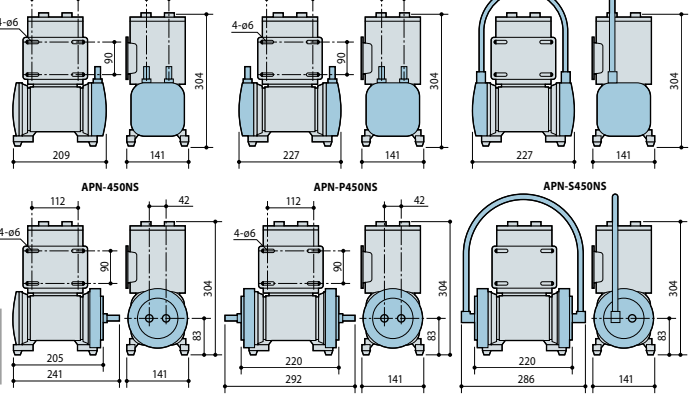

Optional accessory

Filter and Muffler
To be used and muffler when installed at discharge side and also as filter when installed at suction side. (Check valve incorporated filter is available as option)



AF-2V-1C

	1	2	3
1. Materials	V: FKM	E: EPDM	N: CR/NBR(Gasket, O ring, Check valve)
2. Connection	1: G1/8(For type 215)	2: G1/4(For type 085 and 110)	
3. Option	C: With Check valve		

IWAKI CO., LTD. 6-6 Kanda-Sudacho 2-chome Chiyoda-ku Tokyo 101-8558 Japan
TEL: (81)3 3254 2935 FAX: 3 3252 8892

IWAKI has global network. Please find your distributor location at www.iwakupumps.jp

European office : IWAKI Europe GmbH Germany : IWAKI Europe GmbH Holland : IWAKI Europe GmbH (Netherlands Branch) Italy : IWAKI Europe GmbH (Italy Branch) Spain : IWAKI Europe GmbH (Spain Branch) Belgium : IWAKI Belgium N.V. Denmark : IWAKI Nordic A/S Finland : IWAKI Suomi Oy France : IWAKI France S.A. Norway : IWAKI Norge AS Sweden : IWAKI Sverige AB U.K. : IWAKI Pumps (UK) Ltd.	TEL: (49)2154 9254 0 TEL: (49)2154 9254 50 TEL: (31)74 2420011 TEL: (39)0444 371115 TEL: (34)93 37 70 198 TEL: (32)13 67 02 00 TEL: (45)48 24 2345 TEL: (358)9 2745810 TEL: (33)1 69 63 33 70 TEL: (47)23 38 49 00 TEL: (46)8 511 72900 TEL: (44)1743 231363	FAX: 2154 9254 48 FAX: 2154 9254 55 FAX: (49)2154 925448 FAX: 0444 335350 FAX: 93 47 40 991 FAX: 13 67 20 30 FAX: 48 24 2346 FAX: 9 2742715 FAX: 1 64 49 92 73 FAX: 23 38 49 01 FAX: 8 511 72922 FAX: 1743 366507	U.S.A. : IWAKI America Inc. Argentina : IWAKI America Inc. (Argentina Branch) Singapore : IWAKI Singapore Pte Ltd. Indonesia : IWAKI Singapore (Indonesia Branch) Malaysia : IWAKI M Sdn. Bhd. Australia : IWAKI Pumps Australia Pty Ltd. Hong Kong : IWAKI Pumps Co., Ltd. China : GFTZ IWAKI Engineering & Trading Co., Ltd. : IWAKI Pumps (Shanghai) Co., Ltd. Korea : IWAKI Korea Co., Ltd. Taiwan : IWAKI Pumps Taiwan Co., Ltd. Thailand : IWAKI (Thailand) Co., Ltd. Vietnam : IWAKI Pumps Vietnam Co., Ltd.	TEL: (1)508 429 1440 TEL: (54)11 4745 4116 TEL: (65)6316 2028 TEL: (62)21 6906606 TEL: (60)3 7803 8807 TEL: (61)2 9899 2411 TEL: (852)2607 1168 TEL: (86)20 84350603 TEL: (86)21 6272 7502 TEL: (82)2 2630 4800 TEL: (886)2 8227 6900 TEL: (66)2 322 2471 TEL: (84)613 933456	FAX: 508 429 1386 FAX: 6316 3221 FAX: 21 6906612 FAX: 3 7803 4800 FAX: 2 9899 2421 FAX: 2607 1000 FAX: 20 84359181 FAX: 21 6272 6929 FAX: 2 2630 4801 FAX: 2 8227 6818 FAX: 2 322 2477 FAX: 613 933399
--	---	--	--	---	---

⚠ Caution for safety use:
Before use of pump, read instruction manual carefully to use the product correctly.

Actual pumps may differ from the photos.
Specifications and dimensions are subject to change without prior notice.
For further details please contact us.

⚠ Legal attention related to export. Our products and/or parts of products fall in the category of goods contained in control list of international regime for export control. Please be reminded that export license could be required when products are exported due to export control regulations of countries.

